

JIS F2015-1987 Cast Steel Bar Type Chain Stopper



When the vessel mooring ,chain stopper transport the pull strength of anchor and chain to vessel, can reduce the working load protect the anchor windlass. When sailing it stand the anchor weight and inertial force.

Process:casting,forging, welding

Finish: anti-rust paint

Withstand 80% of Chain Cable's breaking load

Drawing:

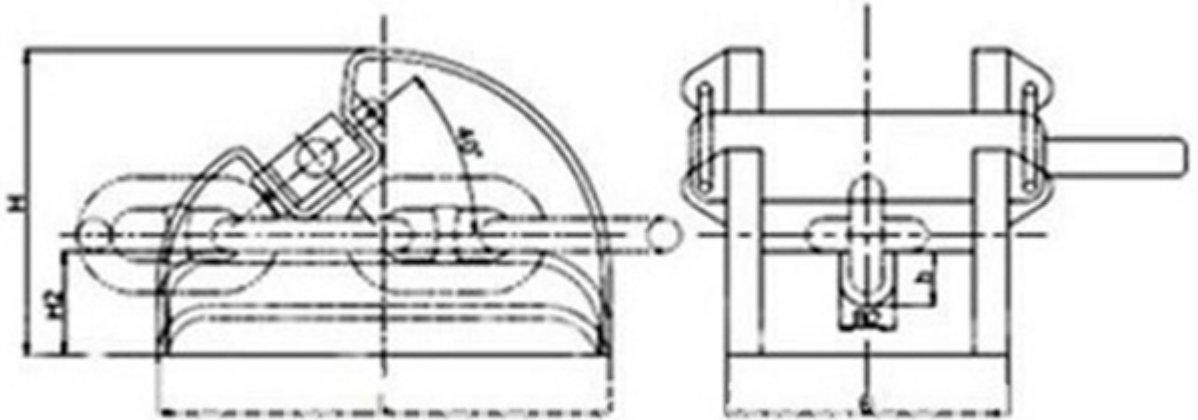

Size chart:

Chain Dia.(mm)	Dimensions(mm)						Weight(KG)
	B	H	H2	L	h	B2	
38-40	336	378	130	540	68	65	110
42-44	366	412	142	590	75	72	138
46-48	397	450	155	640	82	78	177
50-52	428	491	170	695	88	85	214
54-56	457	528	182	745	95	92	261
58-60	488	465	195	795	102	98	319
62-64	517	600	208	850	109	104	396
66-68	547	635	220	900	116	110	428
70-73	582	675	233	960	125	117	609
76-78	617	715	245	1020	133	123	740

Size 62mm to 78mm counter-weight shall be equipped.

The bar can be opened in right or left hand side.