

# Jinbo Marine

Marine &amp; Offshore Equipment Datasheet

PRODUCT DATASHEET

## CHJ ENGINEER SAFETY ALARM SYSTEM

# 6/12KD-3ZG Engineer Alarm Main Unit

6/12KD-3ZG Engineer Alarm Main Unit Output power: ≤20W ( 6 door ) ≤40W ( 12door )  
 Sound pressure level of calling and alarm: 80dB~ 95dB Main power: DC24V -25% +30%  
 Emergency power: DC2...

ISO9001 Supplier

Class Certificate

Export Supply



### Key Highlights

Category	CHJ Engineer Safety Alarm System
Standard	EN
Weight / Size	Black ( RAL9005 ) IP class:IP22 Weight:3.8Kg Power:15W/20W
Certificate	ABS, LR, BV, DNVGL, NK, KR, IRS, RMRS, CCS

We can supply according to your requirement, drawings, class certificate needs, and delivery schedule.

### Technical Specifications

Category	CHJ Engineer Safety Alarm System	Model / SKU	6-12KD-3ZG-Engineer-Alarm-Main-Unit
Standard	EN	Weight / Size	Black ( RAL9005 ) IP class:IP22 Weight:3.8Kg Power:15W/20W
Certificate	ABS, LR, BV, DNVGL, NK, KR, IRS, RMRS, CCS	Warranty	12 Months unless specified otherwise
Origin	China		

## China 6/12KD-3ZG Engineer Alarm Main Unit:

6/12KD-3ZG Engineer Alarm Main Unit

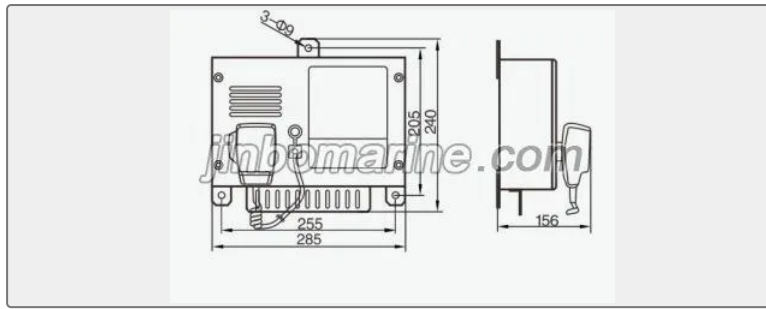

Output power:  $\leq 20W$  ( 6 door )  $\leq 40W$  ( 12door )

Sound pressure level of calling and alarm: 80dB~ 95dB

Main power: DC24V -25% +30%

Emergency power: DC24V -25% +30%

Passive contact load(resistance): 8A/250VAC

Capacity: 6/12 door

Color: Black ( RAL9005 )

IP class: IP22

Weight: 3.8Kg

Power: 15W/20W