

LIFE-SAVING LIGHT

## AL60-A6N3-A Audible Visual Alarm

Product Description The AL60 series is an efficient integrated alarm device designed to meet the audible-visual alert needs in industrial scenarios. It is suitable for environments such as factories, el...

ISO9001 Supplier

Class Certificate

Export Supply



Key Highlights	
Category	Life-Saving Light
Standard	EN
Material	Product Features PC/ABS housing, compact and lightweight 32 selectable t...
Weight / Size	Product Features PC/ABS housing, compact and lightweight 32 selectable t...
Certificate	ABS, LR, BV, DNVGL, NK, KR, IRS, RMRS, CCS
We can supply according to your requirement, drawings, class certificate needs, and delivery schedule.	

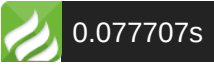

Technical Specifications			
<b>Category</b>	Life-Saving Light	<b>Model / SKU</b>	AL60-A6N3-A-Audible-Visual-Alarm
<b>Standard</b>	EN	<b>Material</b>	Product Features PC/ABS housing, compact and lightweight 32 selectable tones Adjustable volume, up to 106dB High-brightness LED with over 100,000 hours lifespan Supports synchronized and separate sound and light control Operating voltage 100-240VAC 50/60Hz Power consumption < 10W Alarm mode:Audible visible synchronized Wiring:G3/4 cable gland Light patterns Flash LED Red color LEDs lifetime 100,000h Housing material ABS Cover material PC Weight 0.75kg Mounting Wall mount Operating temperature-25°C ~ +60°C
<b>Weight / Size</b>	Product Features PC/ABS housing, compact and lightweight 32 selectable tones Adjustable volume, up to 106dB High-brightness LED with over 100,000 hours lifespan Supports synchronized and separate sound and light control Operating voltage 100-240VAC 50/60Hz Power consumption < 10W Alarm mode:Audible visible synchronized Wiring:G3/4 cable gland Light patterns Flash LED Red color LEDs lifetime 100,000h Housing material ABS Cover material PC Weight 0.75kg Mounting Wall mount Operating temperature-25°C ~ +60°C	<b>Certificate</b>	ABS, LR, BV, DNVGL, NK, KR, IRS, RMRS, CCS
<b>Warranty</b>	12 Months unless specified otherwise	<b>Origin</b>	China

**CONTENTS**

- Product Description

- Product Features

## Product Description

The AL60 series is an efficient integrated alarm device designed to meet the audible-visual alert needs in



0.077707s

industrial scenarios. It is suitable for environments such as factories, electrical rooms, driver cabins, and ship cabins, and can also serve as a terminal device for various alarm signals.

## Product Features

PC/ABS housing, compact and lightweight

32 selectable tones

Adjustable volume, up to 106dB

High-brightness LED with over 100,000 hours lifespan

Supports synchronized and separate sound and light control

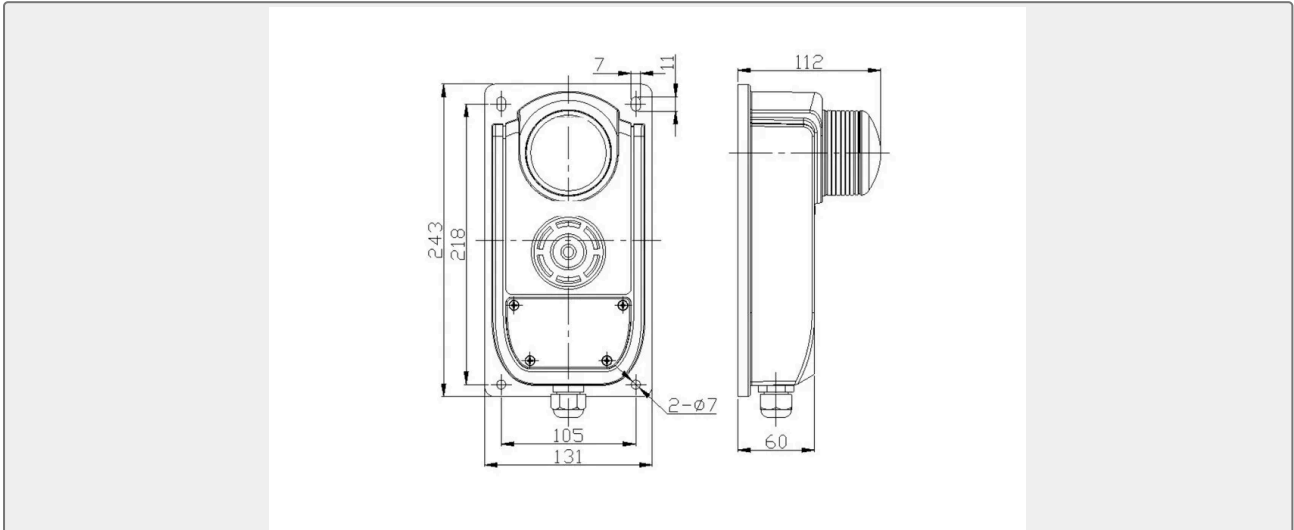

Operating voltage 100-240VAC 50/60Hz

Power consumption < 10W

Alarm mode: Audible visible synchronized

Wiring: G3/4 cable gland

Light patterns Flash

LED Red color

LEDs lifetime 100,000h

Housing material ABS

Cover material PC

Weight 0.75kg

Mounting Wall mount

Operating temperature -25°C ~ +60°C