

CHJ MAN OVERBOARD ALARM SYSTEM

AN-6Q Reset Button

AN-6Q Reset Button Color: Black (RAL9005) IP class:IP20 Weight:0.3Kg

ISO9001 Supplier

Class Certificate

Export Supply



Key Highlights

Category	CHJ Man Overboard Alarm System
Weight / Size	Black (RAL9005) IP class:IP20 Weight:0.3Kg
Certificate	ABS, LR, BV, DNVGL, NK, KR, IRS, RMRS, CCS

We can supply according to your requirement, drawings, class certificate needs, and delivery schedule.

Technical Specifications

Category	CHJ Man Overboard Alarm System	Model / SKU	AN-6Q-Reset-Button
Weight / Size	Black (RAL9005) IP class:IP20 Weight:0.3Kg	Certificate	ABS, LR, BV, DNVGL, NK, KR, IRS, RMRS, CCS
Warranty	12 Months unless specified otherwise	Origin	China

China AN-6Q Reset Button:

AN-6Q Reset Button

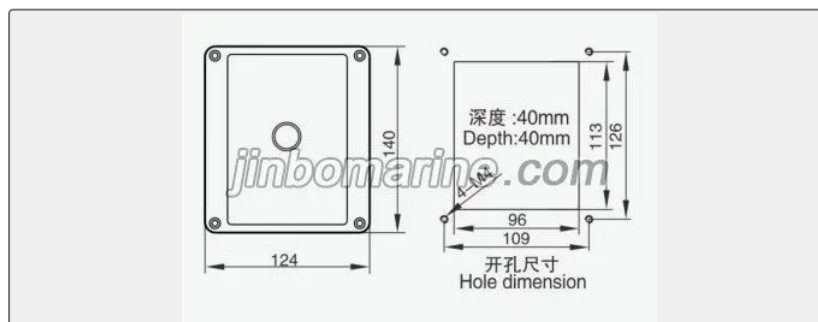

Color: Black (RAL9005)

IP class:IP20

Weight:0.3Kg