

Jinbo Marine

Marine & Offshore Equipment Datasheet

PRODUCT DATASHEET

MARINE BATTERYLESS TELEPHONE SYSTEM

AQ-3 Safety Barrier

AQ-3 Safety Barrier Be used for Single-way batteryless telephone) Color: black (RAL9005) Explosion-proof class:[Ex ib Gb]II B IP class:IP44 Weight:1.1Kg Stuffing bo...

- ISO9001 Supplier
- Class Certificate
- Export Supply



Key Highlights

Category	Marine Batteryless Telephone System
Standard	GB
Weight / Size	black (RAL9005) Explosion-proof class:[Ex ib Gb]II B IP class:IP44 Weight...
Certificate	ABS, LR, BV, DNVGL, NK, KR, IRS, RMRS, CCS

We can supply according to your requirement, drawings, class certificate needs, and delivery schedule.

Technical Specifications

Category	Marine Batteryless Telephone System	Model / SKU	AQ-3-Safety-Barrier
Standard	GB	Weight / Size	black (RAL9005) Explosion-proof class:[Ex ib Gb]II B IP class:IP44 Weight:1.1Kg Stuffing box cable entrance hole size:
Certificate	ABS, LR, BV, DNVGL, NK, KR, IRS, RMRS, CCS	Warranty	12 Months unless specified otherwise
Origin	China		

China AQ-3 Safety Barrier:

AQ-3 Safety Barrier

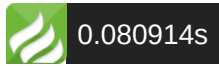

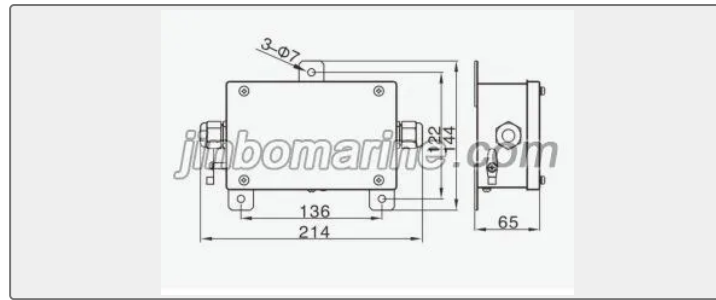

Be used for Single-way batteryless telephone)

Color: black (RAL9005)

Explosion-proof class:[Ex ib Gb]II B

IP class:IP44

Weight:1.1Kg

Stuffing box cable entrance hole size: 2-Φ14mm;