

Jinbo Marine

Marine & Offshore Equipment Datasheet

PRODUCT DATASHEET

MARINE KITCHEN GALLEY

Ansul-R102-20 Marine Deep Frying Pan With Fire Extinguishing System

ISO9001 Supplier

Class Certificate

Export Supply

Ansul-R102-20 Marine Deep Frying Pan With Fire Extinguishing System 1. All stainless steel structure 2 Automatic detection, fire extinguishing, alarm and automatic power-off device 3. Manual emergency start fire ...



Key Highlights

Category	Marine Kitchen Galley
Standard	EN
Material	SS
Weight / Size	Power distribution stainless steel adjustable feet for easy installation...
Certificate	ABS, LR, BV, DNVGL, NK, KR, IRS, RMRS, CCS

We can supply according to your requirement, drawings, class certificate needs, and delivery schedule.



Technical Specifications			
Category	Marine Kitchen Galley	Model / SKU	Ansul-R102-20-Marine-Deep-Frying-Pan-With-Fire-Extinguishing-System
Standard	EN	Material	SS
Weight / Size	Power distribution stainless steel adjustable feet for easy installation on board Ansul-R102-20 Marine Deep Frying Pan With Fire Extinguishing System Drawing Ansul-R102-20 Marine Deep Frying Pan With Fire Extinguishing System Parameters Model MFEX22-10 MFEX22-D20 Ansul-R102-10 Ansul-R102-20 Volume(L) 10 20 10 20 Voltage 380/415V-3PH-50Hz 440/480v 3ph-60Hz Power(kw) 7.1/9 14.2/9 7 14 Size(mm) 500x800x1750 650x800x1750 480x820x1800 780x820x1800 Weight(kg) 105 130 124 158	Certificate	ABS, LR, BV, DNVGL, NK, KR, IRS, RMRS, CCS
Warranty	12 Months unless specified otherwise	Origin	China

CONTENTS			
■ Ansul-R102-20 Marine Deep Frying Pan With Fire Extinguishing System	■ Ansul-R102-20 Marine Deep Frying Pan With Fire Extinguishing System Drawing	■ Ansul-R102-20 Marine Deep Frying Pan With Fire Extinguishing System Parameters	

Ansul-R102-20 Marine Deep Frying Pan With Fire Extinguishing System

1. All stainless steel structure
2. Automatic detection, fire extinguishing, alarm and automatic power-off device
3. Manual emergency start fire extinguishing device
4. Control the normally closed open contact of the external alarm or control the power output
5. Working thermostat, protection temperature limiter failure alarm function
6. Oil pan drain valve with oil storage barrel
7. Anti-wave handrails
8. Power distribution stainless steel adjustable feet for easy installation on board



Ansul-R102-20 Marine Deep Frying Pan With Fire Extinguishing System Drawing

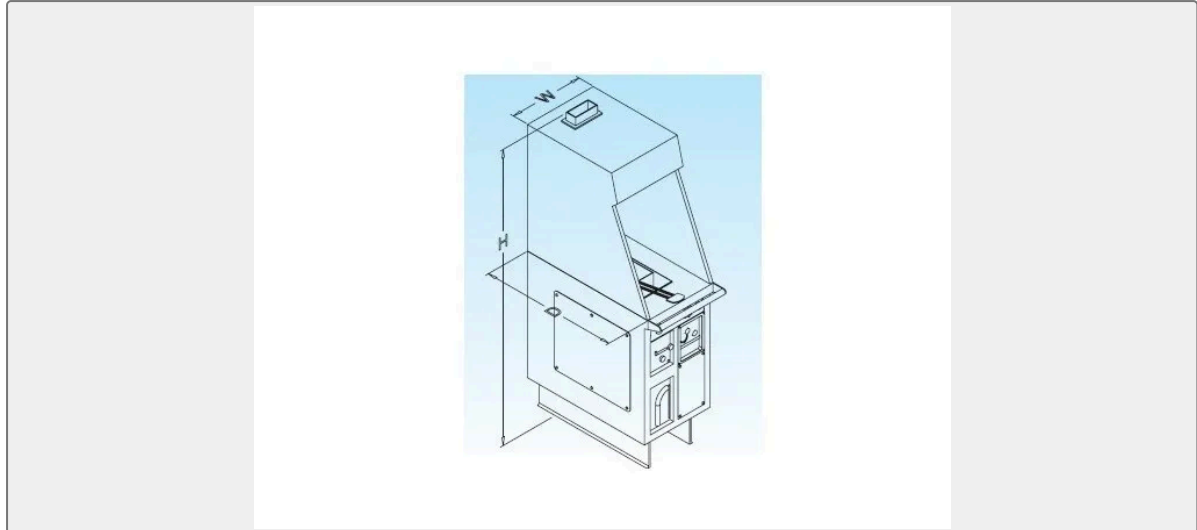

Ansul-R102-20 Marine Deep Frying Pan With Fire Extinguishing System Parameters

Model	MFEX22-10	MFEX22-D20	Ansul-R102-10	Ansul-R102-20
Volume(L)	10	20	10	20
Voltage	380/415V-3PH-50Hz 440/480v 3ph-60Hz			
Power(kw)	7.1/9	14.2/9	7	14
Size(mm)	500x800x1750	650x800x1750	480x820x1800	780x820x1800
Weight(kg)	105	130	124	158