

Jinbo Marine

Marine & Offshore Equipment Datasheet

PRODUCT DATASHEET

MARINE AUTOMATIC TELEPHONE SYSTEM

BX-1 Portable Box

BX-1 Portable Box Color: Black (RAL9005) IP class:IP65 Weight:3.9Kg Applied to Portable auto telephone

ISO9001 Supplier

Class Certificate

Export Supply



Key Highlights

Category	Marine Automatic Telephone System
Weight / Size	Black (RAL9005) IP class:IP65 Weight:3.9Kg Applied to Portable auto telep...
Certificate	ABS, LR, BV, DNVGL, NK, KR, IRS, RMRS, CCS

We can supply according to your requirement, drawings, class certificate needs, and delivery schedule.

Technical Specifications

Category	Marine Automatic Telephone System	Model / SKU	BX-1-Portable-Box
Weight / Size	Black (RAL9005) IP class:IP65 Weight:3.9Kg Applied to Portable auto telephone	Certificate	ABS, LR, BV, DNVGL, NK, KR, IRS, RMRS, CCS
Warranty	12 Months unless specified otherwise	Origin	China

China BX-1 Portable Box:

BX-1 Portable Box



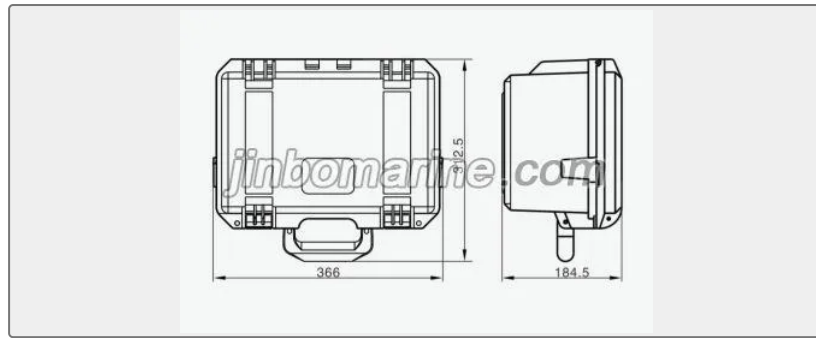

Color: Black (RAL9005)

IP class:IP65

Weight:3.9Kg

Applied to Portable auto telephone