

Jinbo Marine

Marine & Offshore Equipment Datasheet

PRODUCT DATASHEET

MARINE AUTOMATIC TELEPHONE SYSTEM

DHT-1 Outdoor Telephone Booth

DHT-1 Outdoor Telephone Booth&nbsp; Color: Sea gray (B05) Weight:30Kg

ISO9001 Supplier

Class Certificate

Export Supply



Key Highlights

Category	Marine Automatic Telephone System
Weight / Size	Sea gray (B05) Weight:30Kg
Certificate	ABS, LR, BV, DNVGL, NK, KR, IRS, RMRS, CCS

We can supply according to your requirement, drawings, class certificate needs, and delivery schedule.

Technical Specifications

Category	Marine Automatic Telephone System	Model / SKU	DHT-1-Outdoor-Telephone-Booth
Weight / Size	Sea gray (B05) Weight:30Kg	Certificate	ABS, LR, BV, DNVGL, NK, KR, IRS, RMRS, CCS
Warranty	12 Months unless specified otherwise	Origin	China

China DHT-1 Outdoor Telephone Booth:

DHT-1 Outdoor Telephone Booth



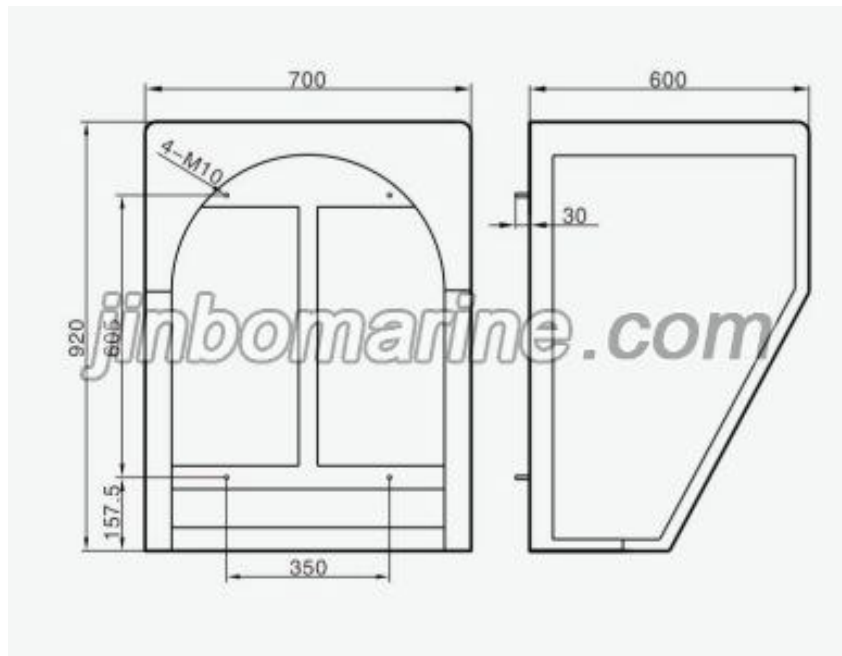

Color: Sea gray (B05)

Weight:30Kg