

Jinbo Marine

Marine & Offshore Equipment Datasheet

PRODUCT DATASHEET

OTHER FIRE-FIGHTING EQUIPMENT

DX-35 Magnetic Drilling Machine

Light and convenient operation, widely used. High power and drilling efficiency. Patented structure, high-precision manufacturing process with long service life. AC220V-240V 50-60HZ

...

ISO9001 Supplier

Class Certificate

Export Supply



Key Highlights

Category	Other Fire-Fighting Equipment
Standard	DIN
Weight / Size	167x84x44mm Machine Size:
Certificate	ABS, LR, BV, DNVGL, NK, KR, IRS, RMRS, CCS

We can supply according to your requirement, drawings, class certificate needs, and delivery schedule.

Technical Specifications

Category	Other Fire-Fighting Equipment	Model / SKU	DX-35-Magnetic-Drilling-Machine
Standard	DIN	Weight / Size	167x84x44mm Machine Size:
Certificate	ABS, LR, BV, DNVGL, NK, KR, IRS, RMRS, CCS	Warranty	12 Months unless specified otherwise
Origin	China		

China DX-35 Magnetic Drilling Machine:

Light and convenient operation, widely used.

High power and drilling efficiency.

Patented structure, high-precision manufacturing process with long service life.



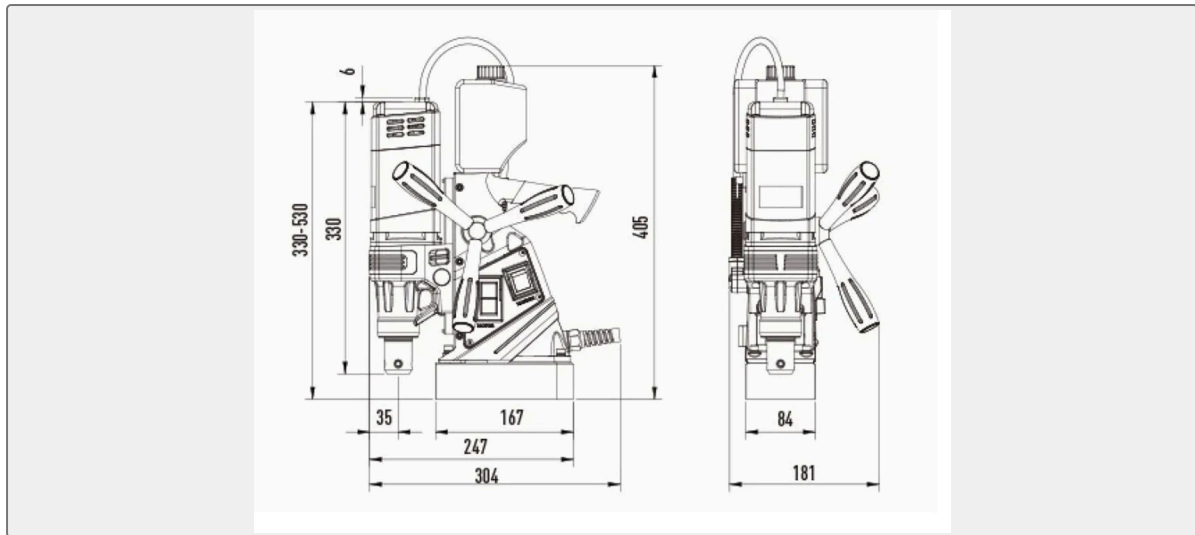

AC220V-240V 50-60HZ

Rated Input Power: 1100w

Magnetic Suction: 10000n

Stroke: 120mm

Mainshaft adjustable Height: 95mm

Spindle Interface Type: 19.05mm

Maghetic Base Side: 167x84x44mm

Machine Size: 304x181x330 (530) mm

The Minimum Processing Thickness:10mm

The Diameter Range Of Annular Cutter:≤35mm

Thecrilung Depth Range Of Annular Cutter:≤50mm

The Diameter Range Of Twist Drill:≤13mm

Apping Specifications

Weght: 10.5kg

Rated Speed: 450rpm

Model	Voltge And Power	Rotation speed	Spindle Interface Type(mm)	The maximum drilling diameter of annular cutter(mm)	The max drilling diameter of twist drill(mm)	Magnetic suction(N)
DX-35	220-240V 1100W 110-127V 1100W	450	19.05(mm) Sliding Plate Stroke:120mm	DOC:50mm,TCT 35mm,HSS 35mm	13mm	10000
DX-H35	220-240V 1100W 110-127V 1100W	450	19.05(mm) Sliding Plate Stroke:63mm	DOC:50mm,TCT 35mm,HSS 35mm	13mm	9000

DX-H35S	220-240V 1100W 110-127V 1100W	450	19.05(mm) Sliding Plate Stroke:63mm	DOC:50mm,TCT 35mm,HSS 35mm	13mm	9000
DX-60	220-240V 1500W 110-127V 1500W	450/250	MT3(mm) Sliding Plate Stroke:170mm	DOC:75mm,TCT 60mm,HSS 50mm	31.5mm	15000
DX-60X	220-240V 1500W 110-127V 1500W	450/250	MT3(mm) Sliding Plate Stroke:170mm	DOC:75mm,TCT 60mm,HSS 50mm	31.5mm	15000
DX-120	220-240V 2500W	80/125/1 75/300	MT4(mm) Sliding Plate Stroke:220mm	DOC:120mm,TCT 65mm,HSS 42mm	42mm	20000
DX-120X	220-240V 2500W 110-127V 2500W	80/125/1 75/300	MT4(mm) Sliding Plate Stroke:220mm	DOC:120mm,TCT 65mm,HSS 42mm	42mm	20000
DR-35	220-240V 1100W 110-127V 1100W	450	19.05(mm) Sliding Plate Stroke:120mm	-	-	-