

Jinbo Marine

Marine & Offshore Equipment Datasheet

PRODUCT DATASHEET

FILTER

GPL24 Model Blade Filter

GPL24 Model Blade Filter The fuel enters the inlet of the filter,through the transfer value into the oil chamber of the filter,and into the cleaning oil chamber through the metal filter core from the outside to the...

ISO9001 Supplier

Class Certificate

Export Supply



Key Highlights

Category	Filter
Standard	EN
Weight / Size	Path Filter precision Work pressure work temperature Suitable medium 1/2...
Certificate	ABS, LR, BV, DNVGL, NK, KR, IRS, RMRS, CCS

We can supply according to your requirement, drawings, class certificate needs, and delivery schedule.

Technical Specifications			
Category	Filter	Model / SKU	GPL24-Model-Blade-Filter
Standard	EN	Weight / Size	Path Filter precision Work pressure work temperature Suitable medium 1/2"-50mm 15um-50um $\leq 1.6\text{MPa}$ $\leq 150^\circ\text{C}$ fuel or heavy oil GPL24 Model Blade Filter Structure Diagram GPL24 Model Blade Filter Technical Parameters Model Caliber and jointing size(mm) Overall size(mm) Installing size(mm) DN E K N-K1 H H1 L W Y b b1 X Z V r R GPL24 24 70 75 8-M10 275 / 290 90 255 15 5 14.5 28 50 7 14
Surface	GPL24 Model Blade Filter The fuel enters the inlet of the filter,through the transfer value into the oil chamber of the filter,and into the cleaning oil chamber through the metal filter core from the outside to the inside,then into the fuel system of diesel engine,the pressure difference of the inlet and the outlet of the filter is 0.05-0.10MPa.the handle must be turned a round anticlockwise,the dirt on the surface of the metal core is bladed,the pressure difference falls,if the result is not good,the metal core can be disaesmbled and washed.	Certificate	ABS, LR, BV, DNVGL, NK, KR, IRS, RMRS, CCS
Warranty	12 Months unless specified otherwise	Origin	China

CONTENTS	■ GPL24 Model Blade Filter	■ GPL24 Model Blade Filter Structure Diagram
	■ GPL24 Model Blade Filter Technical Parameters	

GPL24 Model Blade Filter

The fuel enters the inlet of the filter,through the transfer value into the oil chamber of the filter,and into the cleaning oil chamber through the metal filter core from the outside to the inside,then into the fuel system of diesel engine,the pressure difference of the inlet and the outlet of the filter is 0.05-0.10MPa.the handle must be turned a round anticlockwise,the dirt on the surface of the metal core is bladed,the pressure difference falls,if the result is not good,the metal core can be disaesmbled and washed.

Path	Filter precision	Work pressure	work temperature	Suitable medium
1/2"-50mm	15um-50um	≤1.6MPa	≤150°C	fuel or heavy oil

GPL24 Model Blade Filter Structure Diagram

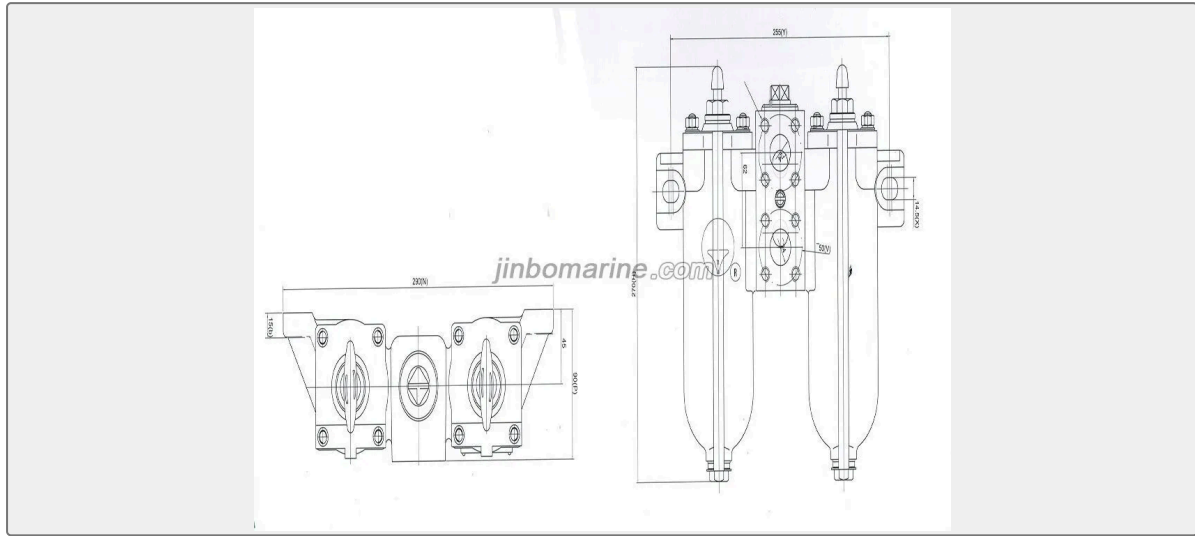

GPL24 Model Blade Filter Technical Parameters

Model	Caliber and jointing size(mm)				Overall size(mm)				Installing size(mm)							
	DN	E	K	N-K1	H	H1	L	W	Y	b	b1	X	Z	V	r	R
GPL24	24	70	75	8-M10	275	/	290	90	255	15	5	14.5	28	50	7	14