

Jinbo Marine

Marine & Offshore Equipment Datasheet

PRODUCT DATASHEET

MARINE OIL WATER SEPERATOR

HBN Series 15PPM Bilge Separator Oily Water Separator

ISO9001 Supplier

Class Certificate

Export Supply

Description: With more and more strict requirements for environmental protection, our company has developed hBN series of oil-water separators for fishing boats suitable for ocean, river and lake. The ...



Key Highlights

Category	Marine Oil Water Seperator
Standard	EN
Material	SS316,SS304, Steel
Weight / Size	The cabin is small in size, compact in structure, easy to operate, long ...
Certificate	CCS

We can supply according to your requirement, drawings, class certificate needs, and delivery schedule.

Technical Specifications

Category	Marine Oil Water Seperator	Model / SKU	HBN-Series-15PPM-Bilge-Separator-Oily-Water-Separator
Standard	EN	Material	SS316,SS304, Steel
Weight / Size	The cabin is small in size, compact in structure, easy to operate, long in service life, and low in spare parts maintenance cost.	Certificate	CCS
Warranty	12 Months unless specified otherwise	Origin	China

CONTENTS

- Description:
- System schematic diagram:
- Technical data:
- Packing:



Description:

With more and more strict requirements for environmental protection, our company has developed hBN series of oil-water separators for fishing boats suitable for ocean, river and lake.

The cabin is small in size, compact in structure, easy to operate, long in service life, and low in spare parts maintenance cost. It is exported to Southeast Asia, Indonesia, Malaysia, Vietnam, Myanmar, Singapore, New Zealand, where a large number of fishing boats use our products, which can provide CCS certificates and meet the standard of IMO mepc.107 (49).

This product is economical, welcome shipowner shipyard friend, ship management company purchase replacement.

System schematic diagram:

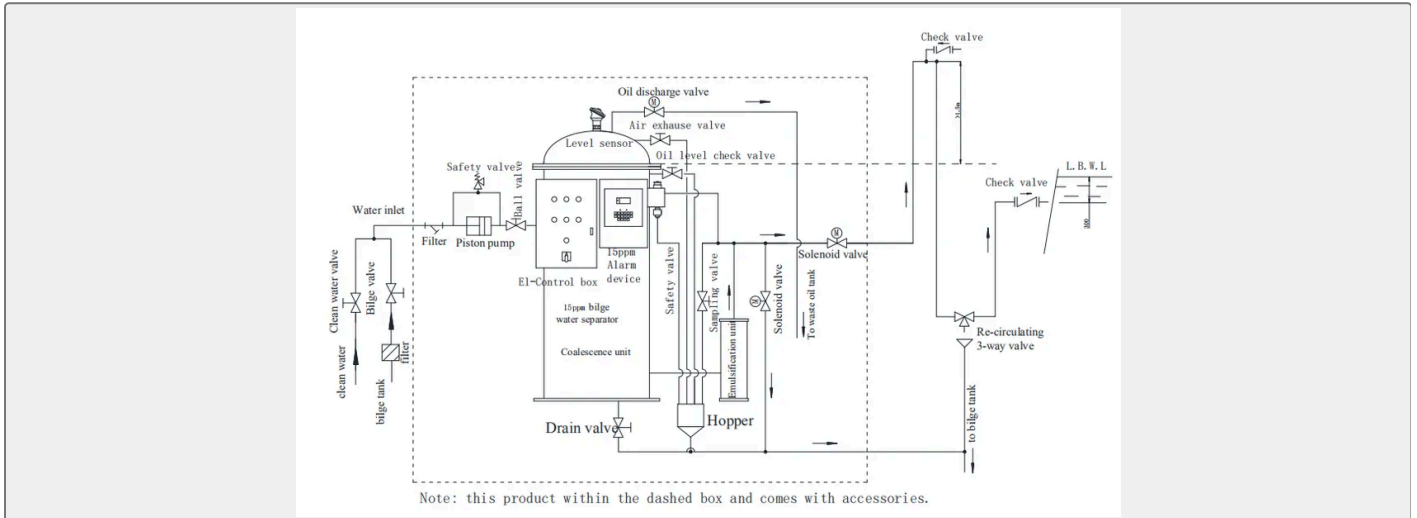

Technical data:

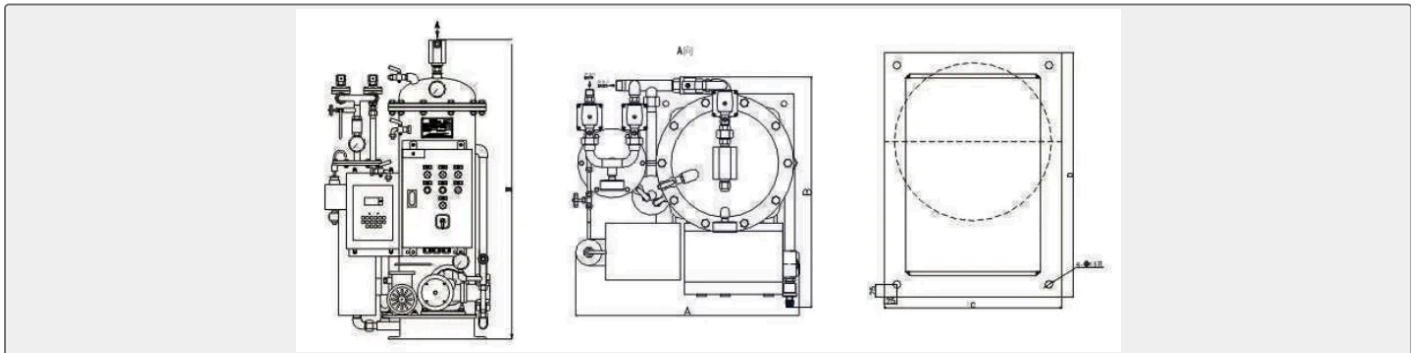

Model	Capacity m3/h	Internal Pressure MPa		Piston Pump	Size					Weight Kg
		Normal	Design		H	A	B	C	D	
HBN-0.1	0.1	0.07	0.3	DZB-100 0.3MPa 0.1m3/h	1070	590	580	350	480	120
HBN-0.25	0.25	0.07	0.3	DZB-250 0.3MPa 0.25m3/h	1236	709	707	484	695	155
HBN-0.5	0.5	0.07	0.3	DZB-500 0.3MPa 0.5m3/h	1400	1010	910	950	810	185
HBN-1.0	1.0	0.07	0.3	DZB-1000 0.3MPa 1.0m3/h	-	-	-	-	-	330
HBN-2.0	2.0	0.12	0.3	DZB-2000 0.3MPa 2.0m3/h	-	-	-	-	-	417



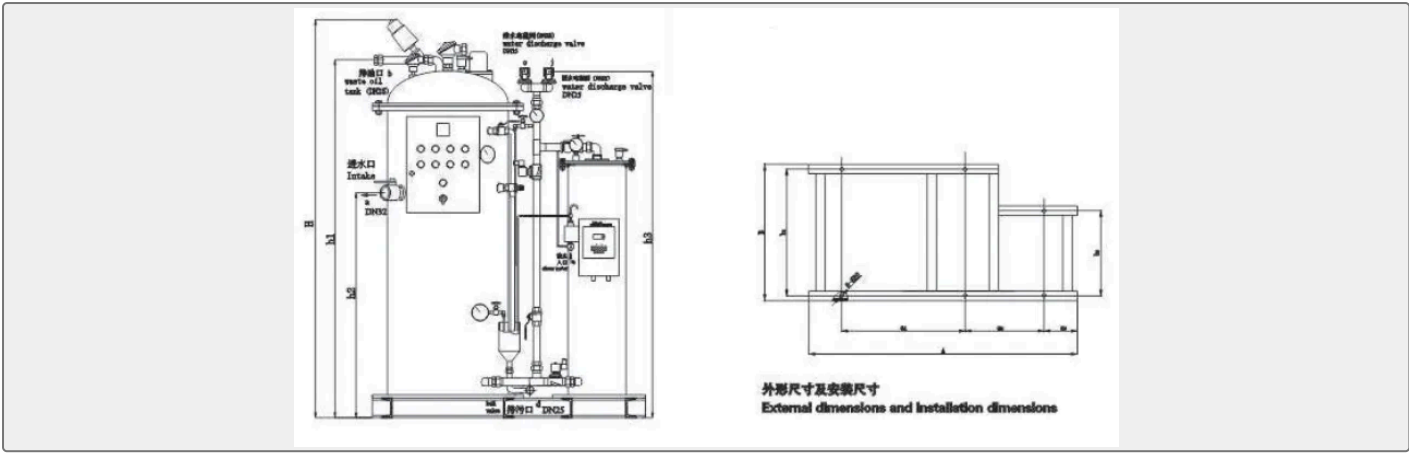

Model	Size									
	H	h1	h2	A	a1	a2	a3	B	b1	b2
HBN-1.0	1390	1250	830	1146	488	358	150	554	511	385
HBN-2.0	1475	1350	930	1204	545	358	150	618	575	385

Packing:

