

Jinbo Marine

Marine & Offshore Equipment Datasheet

PRODUCT DATASHEET

MARINE NAVIGATION EQUIPMENT

HLD-MU600 Main Unit

HLD-MU600 Main Unit Power input: AC110/220V、 50-60Hz;DC 24V Consumption:<150W
Reserve battery:7AH for not less than 2hours usgae Inputs:Audio:5x audio channels;8x
Microphon...

ISO9001 Supplier

Class Certificate

Export Supply



Key Highlights

Category	Marine Navigation Equipment
Standard	DIN
Weight / Size	Integral Long Term Recording Storage Medium Dimensions (LxWxH):
Certificate	ABS, LR, BV, DNVGL, NK, KR, IRS, RMRS, CCS

We can supply according to your requirement, drawings, class certificate needs, and delivery schedule.

Technical Specifications

Category	Marine Navigation Equipment	Model / SKU	HLD-MU600-Main-Unit
Standard	DIN	Weight / Size	Integral Long Term Recording Storage Medium Dimensions (LxWxH):
Certificate	ABS, LR, BV, DNVGL, NK, KR, IRS, RMRS, CCS	Warranty	12 Months unless specified otherwise
Origin	China		

China HLD-MU600 Main Unit:

HLD-MU600 Main Unit



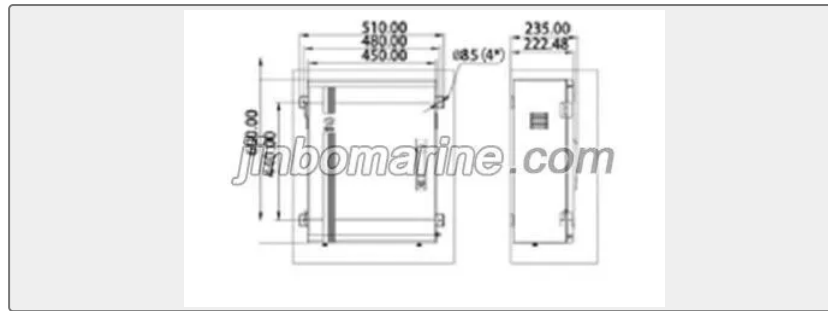

Power input: AC110/220V、 50-60Hz;DC 24V

Consumption:<150W

Reserve battery:7AH for not less than 2hours usgae

Inputs:Audio:5x audio channels;8x Microphone input;2x VHF audio input

Ethernet:10x Ethernet channels(100MBS)for ECDIS,RADAR,etc.

Integral Long Term Recording Storage Medium

Dimensions (LxWxH): 600x450x235mm

Weight:27kg

Installation:Wall or bulkhead mounting

IP Proection:IP22

Working temperature:-15°C~55C