

Jinbo Marine

Marine & Offshore Equipment Datasheet

PRODUCT DATASHEET

MARINE BATTERYLESS TELEPHONE SYSTEM

HS-2E Explosion Proof Wall mounted Batteryless telephone

ISO9001 Supplier

Class Certificate

Export Supply

Specification Capacity: 1User/6 User/12 User Color: Surface dull black Shell material: Aluminum Cable gland: PG25; PG16 (Copper) Power supply: DC24V+10% Explosive- proof grade : ...



Key Highlights

Category	Marine Batteryless Telephone System
Standard	GB
Material	Surface dull black Shell material:
Certificate	ABS, LR, BV, DNVGL, NK, KR, IRS, RMRS, CCS

We can supply according to your requirement, drawings, class certificate needs, and delivery schedule.

Technical Specifications

Category	Marine Batteryless Telephone System	Model / SKU	HS-2E-Explosion-Proof-Wall-mounted-Batteryless-telephone
Standard	GB	Material	Surface dull black Shell material:
Surface	Surface dull black Shell material:	Certificate	ABS, LR, BV, DNVGL, NK, KR, IRS, RMRS, CCS
Warranty	12 Months unless specified otherwise	Origin	China



China HS-2E Explosion Proof Wall mounted Batteryless telephone:

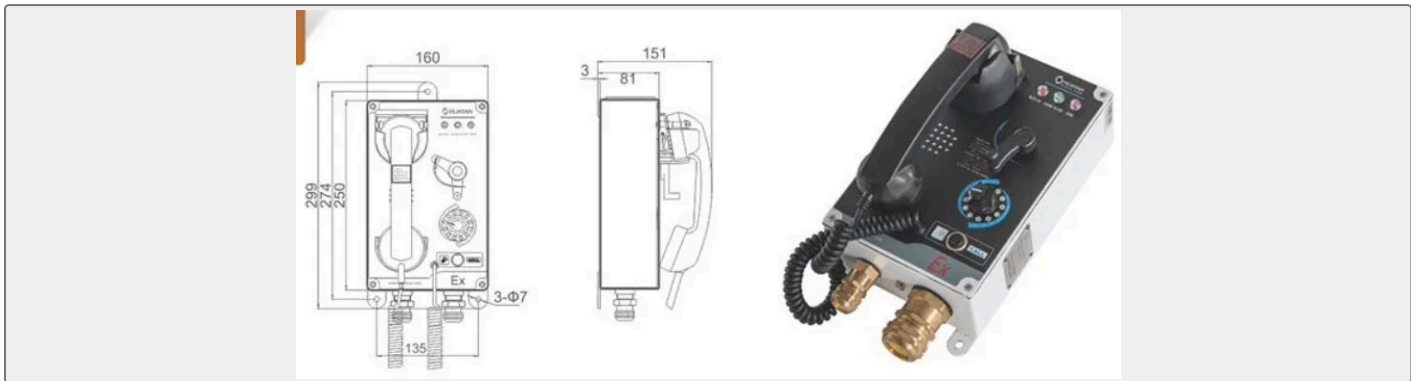

Specification

Capacity: 1User/6 User/12 User

Color: Surface dull black

Shell material: Aluminum

Cable gland: PG25; PG16 (Copper)

Power supply: DC24V+10%

Explosive- proof grade : Exib I CT4 Gb