

EMERGENCY MAIN ENGINE TELEGRAPH SYSTEM

KED12-F-Q/KED12-2F-Q Telegraph Transmitter

- ISO9001 Supplier
- Class Certificate
- Export Supply

KED12-F-Q/KED12-2F-Q Telegraph Transmitter Main power:DC24V -25% +30%
 Emergency power:DC24V -25% +30% Alarm sound pressure level:80dB ~
 90dB Pas...



Key Highlights

Category	Emergency Main Engine Telegraph System
Standard	EN
Weight / Size	black (RAL9005) IP class:IP20 Weight:1.2/1.4Kg Power:5W
Certificate	ABS, LR, BV, DNVGL, NK, KR, IRS, RMRS, CCS

We can supply according to your requirement, drawings, class certificate needs, and delivery schedule.

Technical Specifications			
Category	Emergency Main Engine Telegraph System	Model / SKU	KED12-F-Q-KED12-2F-Q-Telegraph-Transmitter
Standard	EN	Weight / Size	black (RAL9005) IP class:IP20 Weight:1.2/1.4Kg Power:5W
Certificate	ABS, LR, BV, DNVGL, NK, KR, IRS, RMRS, CCS	Warranty	12 Months unless specified otherwise
Origin	China		

China KED12-F-Q/KED12-2F-Q Telegraph Transmitter:

KED12-F-Q/KED12-2F-Q Telegraph Transmitter



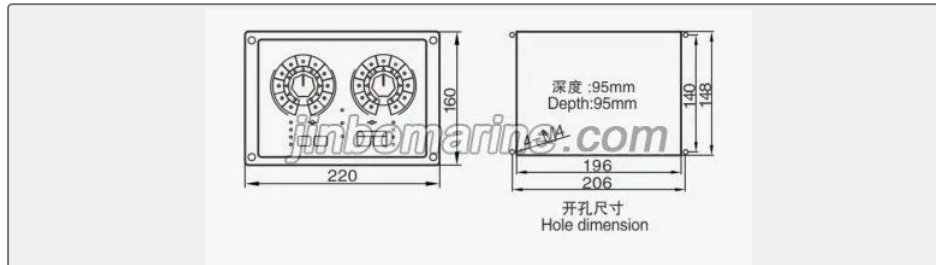
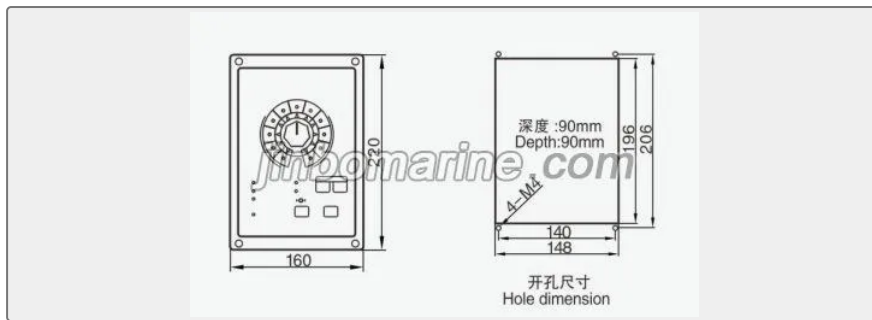

Main power:DC24V -25% +30%

Emergency power:DC24V -25% +30%

Alarm sound pressure level:80dB ~ 90dB

Passive contact load (resistance): 2A/30VDC 1A/125VAC

Maximum shift voltage of passive contact:240VAC/120VDC

Color: black (RAL9005)

IP class:IP20

Weight:1.2/1.4Kg

Power:5W