

# Jinbo Marine

Marine &amp; Offshore Equipment Datasheet

PRODUCT DATASHEET

## MARINE AUTOMATIC TELEPHONE SYSTEM

## KH-1B Explosion-Proof Key Telephone

KH-1B Explosion-Proof Key Telephone &nbsp; &nbsp; &nbsp; Color: Blue ( RAL5015 ) IP class:IP56  
 Weight:1.5Kg Power:1W Explosion-proof class:Exib II B T4Gb Stuffing box cable en...

ISO9001 Supplier

Class Certificate

Export Supply



### Key Highlights

Category	Marine Automatic Telephone System
Standard	GB
Weight / Size	Blue ( RAL5015 ) IP class:IP56 Weight:1.5Kg Power:1W Explosion-proof class:...
Certificate	ABS, LR, BV, DNVGL, NK, KR, IRS, RMRS, CCS

We can supply according to your requirement, drawings, class certificate needs, and delivery schedule.

### Technical Specifications

Category	Marine Automatic Telephone System	Model / SKU	KH-1B-Explosion-Proof-Key-Telephone
Standard	GB	Weight / Size	Blue ( RAL5015 ) IP class:IP56 Weight:1.5Kg Power:1W Explosion-proof class:Exib II B T4Gb Stuffing box cable entrance hole size:
Certificate	ABS, LR, BV, DNVGL, NK, KR, IRS, RMRS, CCS	Warranty	12 Months unless specified otherwise
Origin	China		

### China KH-1B Explosion-Proof Key Telephone:

KH-1B Explosion-Proof Key Telephone



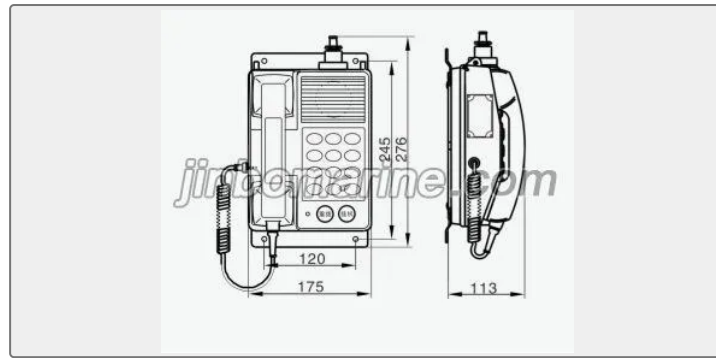

Color: Blue ( RAL5015 )

IP class:IP56

Weight:1.5Kg

Power:1W

Explosion-proof class:Exib II B T4Gb

Stuffing box cable entrance hole size: 1-Φ10mm