

# Jinbo Marine

Marine &amp; Offshore Equipment Datasheet

PRODUCT DATASHEET

## MARINE AUTOMATIC TELEPHONE SYSTEM

# KH-1SF Auto Telephone

KH-1SF Auto Telephone &nbsp; Color: Sea gray ( B05 ) IP class:IP56 Weight:6.5Kg  
Power:1W Tuffing box cable entrancehole size:1-Φ14mm

ISO9001 Supplier

Class Certificate

Export Supply



### Key Highlights

<b>Category</b>	Marine Automatic Telephone System
<b>Standard</b>	EN
<b>Weight / Size</b>	Sea gray ( B05 ) IP class:IP56 Weight:6.5Kg Power:1W Tuffing box cable entr...
<b>Certificate</b>	ABS, LR, BV, DNVGL, NK, KR, IRS, RMRS, CCS

We can supply according to your requirement, drawings, class certificate needs, and delivery schedule.

### Technical Specifications

<b>Category</b>	Marine Automatic Telephone System	<b>Model / SKU</b>	KH-1SF-Auto-Telephone
<b>Standard</b>	EN	<b>Weight / Size</b>	Sea gray ( B05 ) IP class:IP56 Weight:6.5Kg Power:1W Tuffing box cable entrancehole size:1- Φ14mm
<b>Certificate</b>	ABS, LR, BV, DNVGL, NK, KR, IRS, RMRS, CCS	<b>Warranty</b>	12 Months unless specified otherwise
<b>Origin</b>	China		

## China KH-1SF Auto Telephone:

KH-1SF Auto Telephone



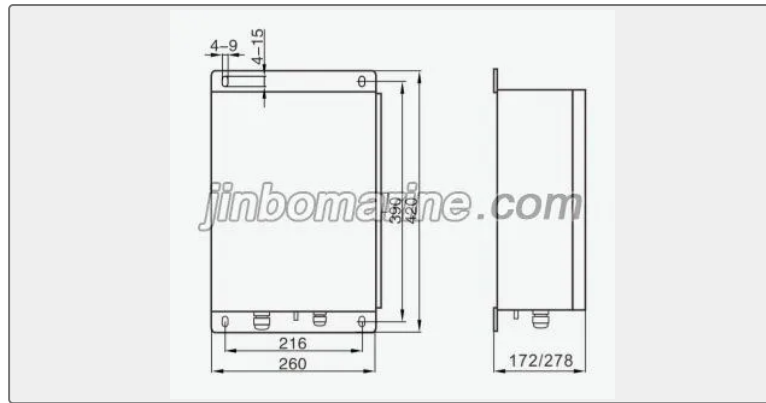

Color: Sea gray ( B05 )

IP class:IP56

Weight:6.5Kg

Power:1W

Tuffing box cable entrancehole size:1- $\Phi$ 14mm