

# Jinbo Marine

Marine &amp; Offshore Equipment Datasheet

PRODUCT DATASHEET

## MARINE AUTOMATIC TELEPHONE SYSTEM

## KH-1SG Auto Telephone

KH-1SG Auto Telephone Color: Black ( RAL9005 ) IP class:IP44 Weight:1.1Kg Power: 1W Stuffing box cable entrance hole size:1-12mm

ISO9001 Supplier

Class Certificate

Export Supply



jinbomarine.com

### Key Highlights

<b>Category</b>	Marine Automatic Telephone System
<b>Standard</b>	EN
<b>Weight / Size</b>	Black ( RAL9005 ) IP class:IP44 Weight:1.1Kg Power:
<b>Certificate</b>	ABS, LR, BV, DNVGL, NK, KR, IRS, RMRS, CCS

We can supply according to your requirement, drawings, class certificate needs, and delivery schedule.

### Technical Specifications

<b>Category</b>	Marine Automatic Telephone System	<b>Model / SKU</b>	KH-1SG-Auto-Telephone
<b>Standard</b>	EN	<b>Weight / Size</b>	Black ( RAL9005 ) IP class:IP44 Weight:1.1Kg Power:
<b>Certificate</b>	ABS, LR, BV, DNVGL, NK, KR, IRS, RMRS, CCS	<b>Warranty</b>	12 Months unless specified otherwise
<b>Origin</b>	China		

### China KH-1SG Auto Telephone:

KH-1SG Auto Telephone

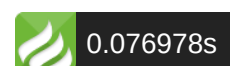

0.076978s

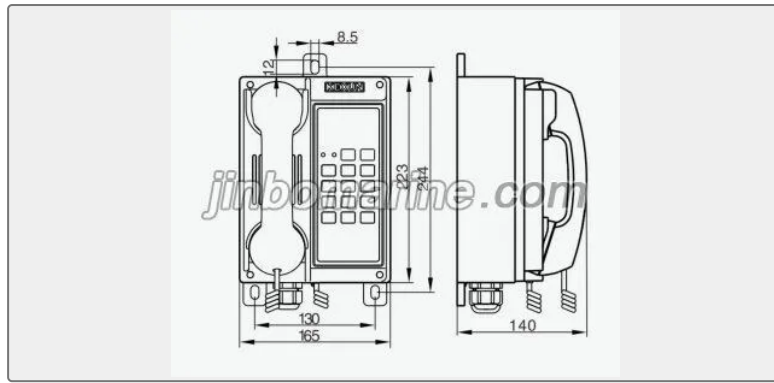

Color: Black ( RAL9005 )

IP class:IP44

Weight:1.1Kg

Power: 1W

Stuffing box cable entrance hole size:1-12mm