

MARINE AUTOMATIC TELEPHONE SYSTEM

KH-1SQ Auto Telephone

KH-1SQ Auto Telephone Color: Black (RAL9005) IP class:IP20 front: IP56 Weight:0.9Kg Power:1W

- ISO9001 Supplier
- Class Certificate
- Export Supply



jinbomarine.com

Key Highlights

| | |
|---|--|
| Category | Marine Automatic Telephone System |
| Weight / Size | IP56 Weight:0.9Kg Power:1W |
| Certificate | ABS, LR, BV, DNVGL, NK, KR, IRS, RMRS, CCS |
| <p>We can supply according to your requirement, drawings, class certificate needs, and delivery schedule.</p> | |

| Technical Specifications | | | |
|--------------------------|--------------------------------------|--------------------|--|
| Category | Marine Automatic Telephone System | Model / SKU | KH-1SQ-Auto-Telephone |
| Weight / Size | IP56 Weight:0.9Kg Power:1W | Certificate | ABS, LR, BV, DNVGL, NK, KR, IRS, RMRS, CCS |
| Warranty | 12 Months unless specified otherwise | Origin | China |

China KH-1SQ Auto Telephone:

KH-1SQ Auto Telephone

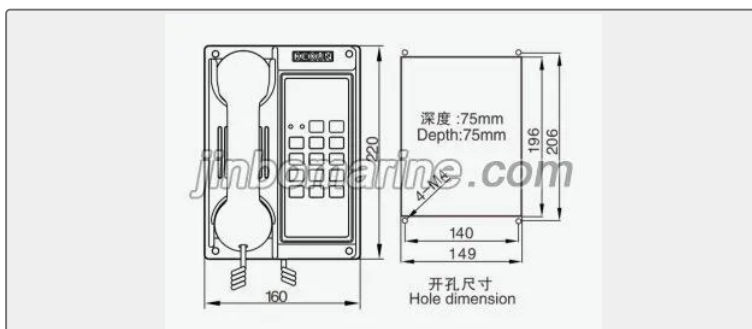

Color: Black (RAL9005)

IP class:IP20 front: IP56

Weight:0.9Kg

Power:1W

