

Jinbo Marine

Marine & Offshore Equipment Datasheet

PRODUCT DATASHEET

MARINE AUTOMATIC TELEPHONE SYSTEM

KH-2SG Auto Telephone

KH-2SG Auto Telephone Color: Black (RAL9005) Voltage : DC24V~DC60V Ringing sound level:>80dB Weight:1.2kg Power : 1W Protection class : IP44 Stuffing box ...

ISO9001 Supplier

Class Certificate

Export Supply



Key Highlights

Category	Marine Automatic Telephone System
Standard	EN
Weight / Size	Black (RAL9005) Voltage : DC24V~DC60V Ringing sound level:>80dB Weight:1.2k...
Certificate	ABS, LR, BV, DNVGL, NK, KR, IRS, RMRS, CCS

We can supply according to your requirement, drawings, class certificate needs, and delivery schedule.

Technical Specifications

Category	Marine Automatic Telephone System	Model / SKU	KH-2SG-Auto-Telephone
Standard	EN	Weight / Size	Black (RAL9005) Voltage : DC24V~DC60V Ringing sound level:>80dB Weight:1.2kg Power : 1W Protection class : IP44 Stuffing box cable entrance hole size:
Certificate	ABS, LR, BV, DNVGL, NK, KR, IRS, RMRS, CCS	Warranty	12 Months unless specified otherwise
Origin	China		

China KH-2SG Auto Telephone:

KH-2SG Auto Telephone



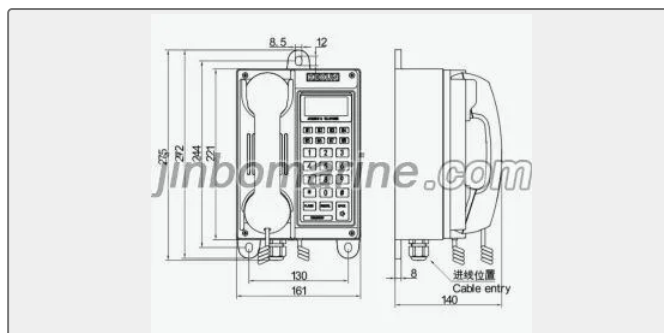

Color: Black (RAL9005)

Voltage : DC24V~DC60V

Ringing sound level:>80dB

Weight:1.2kg

Power : 1W

Protecti on class : IP44

Stuffing box cable entrance hole size: 1-Φ12mm

Headset is optional