

# Jinbo Marine

Marine &amp; Offshore Equipment Datasheet

PRODUCT DATASHEET

## MARINE AUTOMATIC TELEPHONE SYSTEM

## KH-2SQ Auto Telephone

KH-2SQ Auto Telephone Color : Black RAL9005 Voltage : DC24V~DC60V Ringing sound level:>80dB Weight : 0.9kg Power : 1W Protection class : IP20 front: I...

ISO9001 Supplier

Class Certificate

Export Supply



### Key Highlights

<b>Category</b>	Marine Automatic Telephone System
<b>Weight / Size</b>	KH-2SQ Auto Telephone Color : Black RAL9005 Voltage : DC24V~DC60V Ringing ...
<b>Certificate</b>	ABS, LR, BV, DNVGL, NK, KR, IRS, RMRS, CCS

We can supply according to your requirement, drawings, class certificate needs, and delivery schedule.

### Technical Specifications

<b>Category</b>	Marine Automatic Telephone System	<b>Model / SKU</b>	KH-2SQ-Auto-Telephone
<b>Weight / Size</b>	KH-2SQ Auto Telephone Color : Black RAL9005 Voltage : DC24V~DC60V Ringing sound level:>80dB Weight : 0.9kg Power : 1W Protection class : IP20 front:	<b>Certificate</b>	ABS, LR, BV, DNVGL, NK, KR, IRS, RMRS, CCS
<b>Warranty</b>	12 Months unless specified otherwise	<b>Origin</b>	China

### China KH-2SQ Auto Telephone:

KH-2SQ Auto Telephone



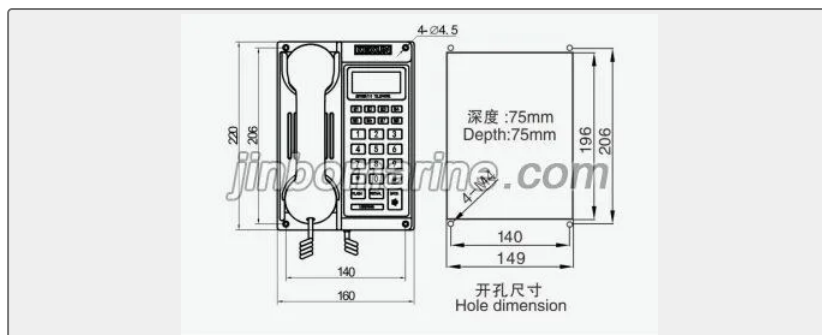

Color : Black RAL9005

Voltage : DC24V~DC60V

Ringing sound level:>80dB

Weight : 0.9kg

Power : 1W

Protecti on class : IP20 front: IP56