

Jinbo Marine

Marine & Offshore Equipment Datasheet

PRODUCT DATASHEET

MARINE AUTOMATIC TELEPHONE SYSTEM

KH-3B Explosion-Proof Auto Telephone

KH-3B Explosion-Proof Auto Telephone Color: Black (RAL9005) Subscriber feedback voltage : 24V~48V Ambient noise: ≤75dB Telephone ringing sound level: ≥85dB Protection ...

ISO9001 Supplier

Class Certificate

Export Supply



Key Highlights

Category	Marine Automatic Telephone System
Standard	GB
Weight / Size	Ex eb ib mb IIC T6 Gb Stuffing box cable entrance hole size:
Certificate	ABS, LR, BV, DNVGL, NK, KR, IRS, RMRS, CCS

We can supply according to your requirement, drawings, class certificate needs, and delivery schedule.

Technical Specifications

Category	Marine Automatic Telephone System	Model / SKU	KH-3B-Explosion-Proof-Auto-Telephone
Standard	GB	Weight / Size	Ex eb ib mb IIC T6 Gb Stuffing box cable entrance hole size:
Certificate	ABS, LR, BV, DNVGL, NK, KR, IRS, RMRS, CCS	Warranty	12 Months unless specified otherwise
Origin	China		

China KH-3B Explosion-Proof Auto Telephone:

KH-3B Explosion-Proof Auto Telephone



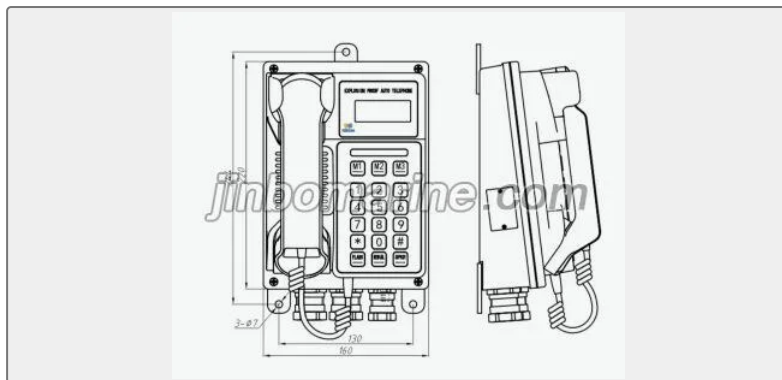

Color: Black (RAL9005)

Subscriber feedback voltage : 24V~48V

Ambient noise:≤75dB

Telephone ringing sound level: ≥85dB

Protection class:IP66

Ex remark: Ex eb ib mb IIC T6 Gb

Stuffing box cable entrance hole size: 2-Φ6~12mm 1-Φ4~8mm

Headset is optional