

# Jinbo Marine

Marine &amp; Offshore Equipment Datasheet

PRODUCT DATASHEET

## MARINE AUTOMATIC TELEPHONE SYSTEM

# KH-4SQ IP Telephone

KH-4SQ IP Telephone Color: Black ( RAL9005 ) Power supply: POE 802.3at Weight: 1.8kg Protection class: IP20

ISO9001 Supplier

Class Certificate

Export Supply



### Key Highlights

<b>Category</b>	Marine Automatic Telephone System
<b>Weight / Size</b>	POE 802.3at Weight:
<b>Certificate</b>	ABS, LR, BV, DNVGL, NK, KR, IRS, RMRS, CCS

We can supply according to your requirement, drawings, class certificate needs, and delivery schedule.

### Technical Specifications

<b>Category</b>	Marine Automatic Telephone System	<b>Model / SKU</b>	KH-4SQ-IP-Telephone
<b>Weight / Size</b>	POE 802.3at Weight:	<b>Certificate</b>	ABS, LR, BV, DNVGL, NK, KR, IRS, RMRS, CCS
<b>Warranty</b>	12 Months unless specified otherwise	<b>Origin</b>	China

## China KH-4SQ IP Telephone:

KH-4SQ IP Telephone



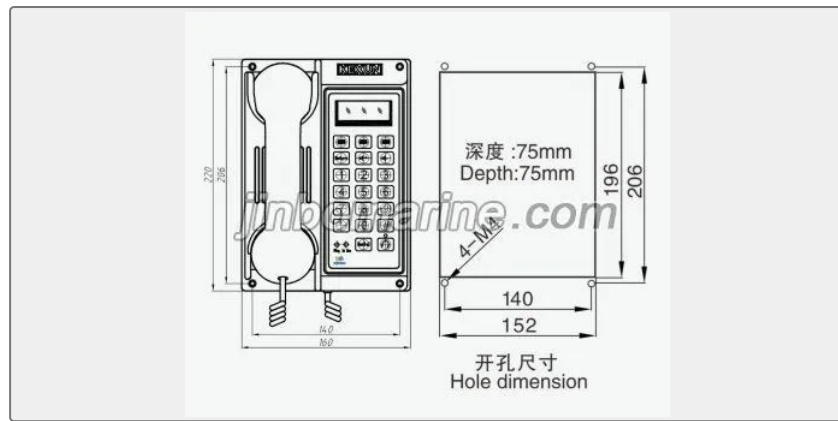

Color: Black ( RAL9005 )

Power supply: POE 802.3at

Weight: 1.8kg

Protection class: IP20