

Jinbo Marine

Marine & Offshore Equipment Datasheet

PRODUCT DATASHEET

HOSPITAL CALLING ALARM SYSTEM

KHC-5FQ Hospital Call Repeater

KHC-5FQ Hospital Call Repeater Operating voltage: DC24V -25% +30% Color: Black (RAL9005) IP class:IP20 Weight:0.3Kg Power:1.5W

ISO9001 Supplier

Class Certificate

Export Supply



Key Highlights

Category	Hospital Calling Alarm System
Weight / Size	Black (RAL9005) IP class:IP20 Weight:0.3Kg Power:1.5W
Certificate	ABS, LR, BV, DNVGL, NK, KR, IRS, RMRS, CCS

We can supply according to your requirement, drawings, class certificate needs, and delivery schedule.

Technical Specifications

Category	Hospital Calling Alarm System	Model / SKU	KHC-5FQ-Hospital-Call-Repeater
Weight / Size	Black (RAL9005) IP class:IP20 Weight:0.3Kg Power:1.5W	Certificate	ABS, LR, BV, DNVGL, NK, KR, IRS, RMRS, CCS
Warranty	12 Months unless specified otherwise	Origin	China

China KHC-5FQ Hospital Call Repeater:

KHC-5FQ Hospital Call Repeater

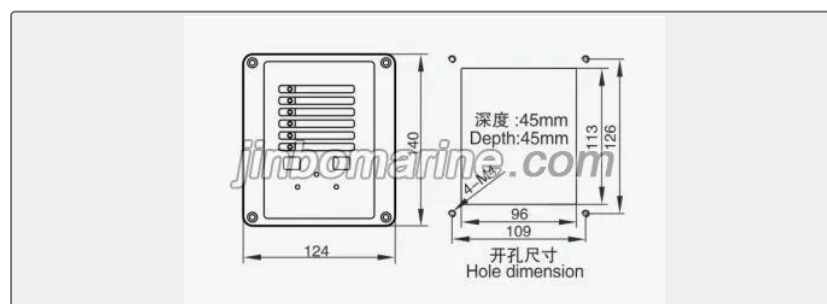

Operating voltage: DC24V -25% +30%

Color: Black (RAL9005)

IP class:IP20

Weight:0.3Kg

Power:1.5W