

# Jinbo Marine

Marine &amp; Offshore Equipment Datasheet

PRODUCT DATASHEET

## HOSPITAL CALLING ALARM SYSTEM

# KHC-5HG Hospital Bathroom Call Unit

KHC-5HG Hospital Bathroom Call Unit Power supply:DC24V -25% +30% Color: Sea gray ( B05 ) IP class:IP56 Weight:0.5Kg Stuffing box cable entrance hole size: 1-Φ14mm

ISO9001 Supplier

Class Certificate

Export Supply



### Key Highlights

Category	Hospital Calling Alarm System
Standard	EN
Weight / Size	Sea gray ( B05 ) IP class:IP56 Weight:0.5Kg Stuffing box cable entrance hol...
Certificate	ABS, LR, BV, DNVGL, NK, KR, IRS, RMRS, CCS

We can supply according to your requirement, drawings, class certificate needs, and delivery schedule.

### Technical Specifications

Category	Hospital Calling Alarm System	Model / SKU	KHC-5HG-Hospital-Bathroom-Call-Unit
Standard	EN	Weight / Size	Sea gray ( B05 ) IP class:IP56 Weight:0.5Kg Stuffing box cable entrance hole size:
Certificate	ABS, LR, BV, DNVGL, NK, KR, IRS, RMRS, CCS	Warranty	12 Months unless specified otherwise
Origin	China		

## China KHC-5HG Hospital Bathroom Call Unit:

KHC-5HG Hospital Bathroom Call Unit

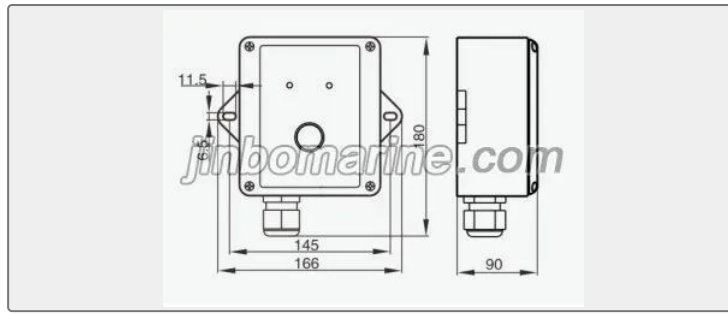

Power supply:DC24V -25% +30%

Color: Sea gray ( B05 )

IP class:IP56

Weight:0.5Kg

Stuffing box cable entrance hole size: 1-Φ14mm