

# Jinbo Marine

Marine & Offshore Equipment Datasheet

PRODUCT DATASHEET

## HOSPITAL CALLING ALARM SYSTEM

# KHC-5Q Hospital Call Controller

KHC-5Q Hospital Call Controller Operating voltage: DC24V -25% +30% Color: Black (RAL9005) IP class:IP20 Weight:0.8Kg Power:≤15W

ISO9001 Supplier

Class Certificate

Export Supply



### Key Highlights

Category	Hospital Calling Alarm System
Weight / Size	Black (RAL9005) IP class:IP20 Weight:0.8Kg Power:≤15W
Certificate	ABS, LR, BV, DNVGL, NK, KR, IRS, RMRS, CCS

We can supply according to your requirement, drawings, class certificate needs, and delivery schedule.

### Technical Specifications

Category	Hospital Calling Alarm System	Model / SKU	KHC-5Q-Hospital-Call-Controller
Weight / Size	Black (RAL9005) IP class:IP20 Weight:0.8Kg Power:≤15W	Certificate	ABS, LR, BV, DNVGL, NK, KR, IRS, RMRS, CCS
Warranty	12 Months unless specified otherwise	Origin	China

## China KHC-5Q Hospital Call Controller:

KHC-5Q Hospital Call Controller

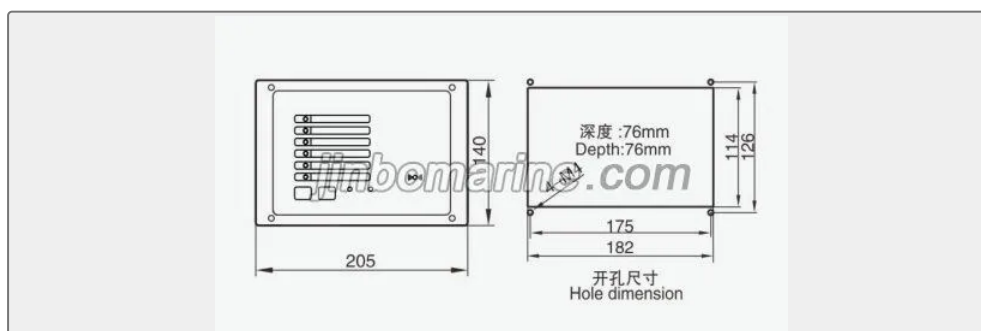

Operating voltage: DC24V -25% +30%

Color: Black ( RAL9005 )

IP class:IP20

Weight:0.8Kg

Power:≤15W