

Jinbo Marine

Marine & Offshore Equipment Datasheet

PRODUCT DATASHEET

EMERGENCY MAIN ENGINE TELEGRAPH SYSTEM

KL-1AG Relay Box With Light And Bell

KL-1AG Relay Box With Light And Bell Power Supply:DC24V -25% +30% Color: Green gray (RAL6034) IP class:IP66 Weight:0.8Kg Sound pressure level: 90dB ~ 105dB Passive co...

ISO9001 Supplier

Class Certificate

Export Supply



Key Highlights

Category	Emergency Main Engine Telegraph System
Standard	EN
Weight / Size	Green gray (RAL6034) IP class:IP66 Weight:0.8Kg Sound pressure level:
Certificate	ABS, LR, BV, DNVGL, NK, KR, IRS, RMRS, CCS

We can supply according to your requirement, drawings, class certificate needs, and delivery schedule.

Technical Specifications

Category	Emergency Main Engine Telegraph System	Model / SKU	KL-1AG-Relay-Box-With-Light-And-Bell
Standard	EN	Weight / Size	Green gray (RAL6034) IP class:IP66 Weight:0.8Kg Sound pressure level:
Certificate	ABS, LR, BV, DNVGL, NK, KR, IRS, RMRS, CCS	Warranty	12 Months unless specified otherwise
Origin	China		

China KL-1AG Relay Box With Light And Bell:

KL-1AG Relay Box With Light And Bell

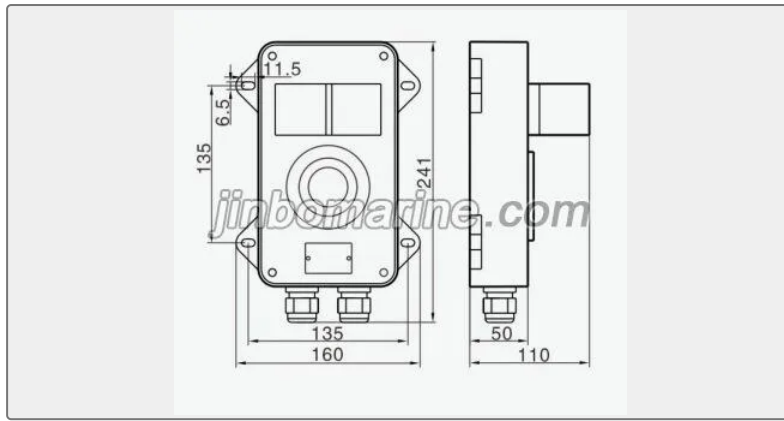

Power Supply:DC24V -25% +30%

Color: Green gray (RAL6034)

IP class:IP66

Weight:0.8Kg

Sound pressure level: 90dB ~ 105dB

Passive contact load(resistance): 2A/30VDC 1A/125VAC

Passive contact maximum switchover voltage: 240VAC/120VDC

Stuffing box cable entrance hole size:2-Φ14mm

Power:5W