

Jinbo Marine

Marine & Offshore Equipment Datasheet

PRODUCT DATASHEET

REFRIGERATOR CALL SYSTEM

KLC-5G Refrigerator Call Controller

KLC-5G Refrigerator Call Controller Operating voltage:DC24V -25% +30% Color: Green gray (RAL7035) IP class:IP44 Weight:3.4Kg Power:≤15W Stuffing box cable entrance h...

ISO9001 Supplier

Class Certificate

Export Supply



Key Highlights

Category	Refrigerator Call System
Standard	EN
Weight / Size	Green gray (RAL7035) IP class:IP44 Weight:3.4Kg Power:≤15W Stuffing box c...
Certificate	ABS, LR, BV, DNVGL, NK, KR, IRS, RMRS, CCS

We can supply according to your requirement, drawings, class certificate needs, and delivery schedule.

Technical Specifications

Category	Refrigerator Call System	Model / SKU	KLC-5G-Refrigerator-Call-Controller
Standard	EN	Weight / Size	Green gray (RAL7035) IP class:IP44 Weight:3.4Kg Power:≤15W Stuffing box cable entrance hole size:
Certificate	ABS, LR, BV, DNVGL, NK, KR, IRS, RMRS, CCS	Warranty	12 Months unless specified otherwise
Origin	China		

China KLC-5G Refrigerator Call Controller:

KLC-5G Refrigerator Call Controller

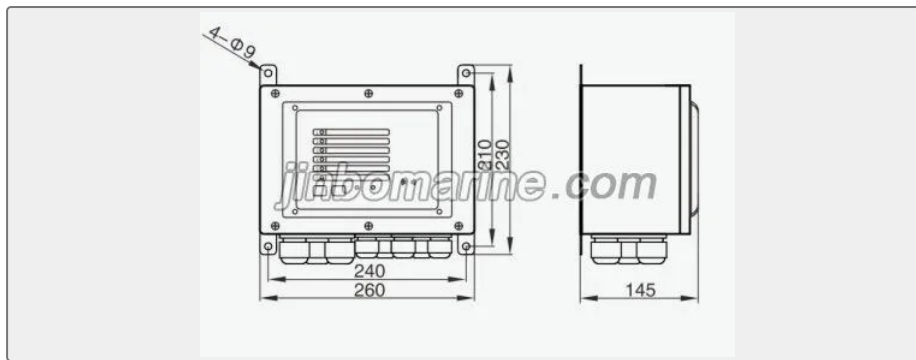

Operating voltage:DC24V -25% +30%

Color: Green gray (RAL7035)

IP class:IP44

Weight:3.4Kg

Power:≤15W

Stuffing box cable entrance hole size: 10-Φ14mm;5-Φ18mm