

REFRIGERATOR CALL SYSTEM

# KLC-5HG Refrigerator Call Unit

KLC-5HG Refrigerator Call Unit Operating voltage:DC24V -25% +30% Color: Sea gray ( B05 ) IP class:IP56 Weight:0.5Kg Power: 1W Stuffing box cable entrance hole size: 1-...

- ISO9001 Supplier
- Class Certificate
- Export Supply



### Key Highlights

Category	Refrigerator Call System
Standard	EN
Weight / Size	Sea gray ( B05 ) IP class:IP56 Weight:0.5Kg Power:
Certificate	ABS, LR, BV, DNVGL, NK, KR, IRS, RMRS, CCS

We can supply according to your requirement, drawings, class certificate needs, and delivery schedule.

Technical Specifications			
<b>Category</b>	Refrigerator Call System	<b>Model / SKU</b>	KLC-5HG-Refrigerator-Call-Unit
<b>Standard</b>	EN	<b>Weight / Size</b>	Sea gray ( B05 ) IP class:IP56 Weight:0.5Kg Power:
<b>Certificate</b>	ABS, LR, BV, DNVGL, NK, KR, IRS, RMRS, CCS	<b>Warranty</b>	12 Months unless specified otherwise
<b>Origin</b>	China		

## China KLC-5HG Refrigerator Call Unit:

KLC-5HG Refrigerator Call Unit

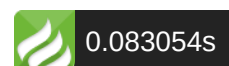
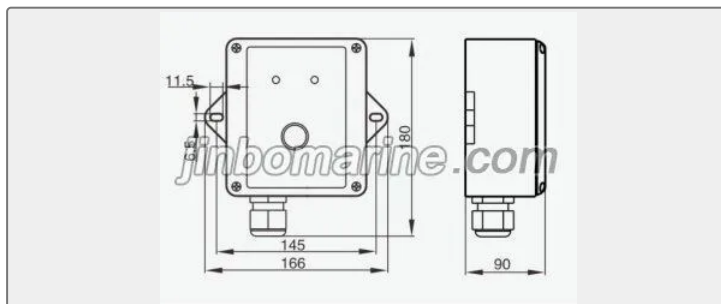

Operating voltage:DC24V -25% +30%

Color: Sea gray ( B05 )

IP class:IP56

Weight:0.5Kg

Power: 1W

Stuffing box cable entrance hole size: 1-Φ14mm