

Jinbo Marine

Marine & Offshore Equipment Datasheet

PRODUCT DATASHEET

REFRIGERATOR CALL SYSTEM

KLC-5Q Refrigerator Call Controller

KLC-5Q Refrigerator Call Controller Operating voltage:DC24V -25% +30% Color: Black (RAL9005) IP class:IP20 Weight:0.8Kg Power:≤15W

ISO9001 Supplier

Class Certificate

Export Supply



Key Highlights

Category	Refrigerator Call System
Weight / Size	Black (RAL9005) IP class:IP20 Weight:0.8Kg Power:≤15W
Certificate	ABS, LR, BV, DNVGL, NK, KR, IRS, RMRS, CCS

We can supply according to your requirement, drawings, class certificate needs, and delivery schedule.

Technical Specifications

Category	Refrigerator Call System	Model / SKU	KLC-5Q-Refrigerator-Call-Controller
Weight / Size	Black (RAL9005) IP class:IP20 Weight:0.8Kg Power:≤15W	Certificate	ABS, LR, BV, DNVGL, NK, KR, IRS, RMRS, CCS
Warranty	12 Months unless specified otherwise	Origin	China

China KLC-5Q Refrigerator Call Controller:

KLC-5Q Refrigerator Call Controller

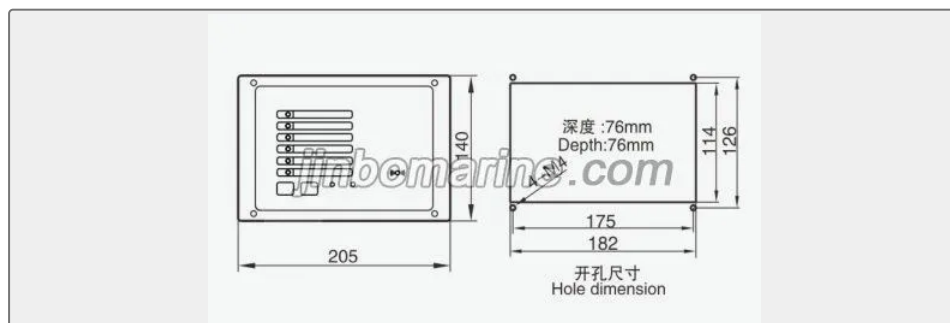

Operating voltage:DC24V -25% +30%

Color: Black (RAL9005)

IP class:IP20

Weight:0.8Kg

Power:≤15W