

Jinbo Marine

Marine & Offshore Equipment Datasheet

PRODUCT DATASHEET

GENERAL EMERGENCY ALARM SYSTEM

KY-1A/B/C Alarm Bell Control Box

KY-1A/B/C Alarm Bell Control Box Power:400/600W (DC24V output) 1000W (AC220V output) Color: Sea gray (B05) IP class:IP22 Weight:16/20/12Kg...

- ISO9001 Supplier
- Class Certificate
- Export Supply

	Key Highlights					
	<table border="1" style="width: 100%; border-collapse: collapse;"> <tr> <td style="width: 20%;">Category</td> <td>General Emergency Alarm System</td> </tr> <tr> <td>Weight / Size</td> <td>Sea gray (B05) IP class:IP22 Weight:16/20/12Kg Power:≤500/750W</td> </tr> <tr> <td>Certificate</td> <td>ABS, LR, BV, DNVGL, NK, KR, IRS, RMRS, CCS</td> </tr> </table>	Category	General Emergency Alarm System	Weight / Size	Sea gray (B05) IP class:IP22 Weight:16/20/12Kg Power:≤500/750W	Certificate
Category	General Emergency Alarm System					
Weight / Size	Sea gray (B05) IP class:IP22 Weight:16/20/12Kg Power:≤500/750W					
Certificate	ABS, LR, BV, DNVGL, NK, KR, IRS, RMRS, CCS					
<p>We can supply according to your requirement, drawings, class certificate needs, and delivery schedule.</p>						

Technical Specifications			
Category	General Emergency Alarm System	Model / SKU	KY-1A-B-C-Alarm-Bell-Control-Box
Weight / Size	Sea gray (B05) IP class:IP22 Weight:16/20/12Kg Power:≤500/750W	Certificate	ABS, LR, BV, DNVGL, NK, KR, IRS, RMRS, CCS
Warranty	12 Months unless specified otherwise	Origin	China

China KY-1A/B/C Alarm Bell Control Box:

KY-1A/B/C Alarm Bell Control Box

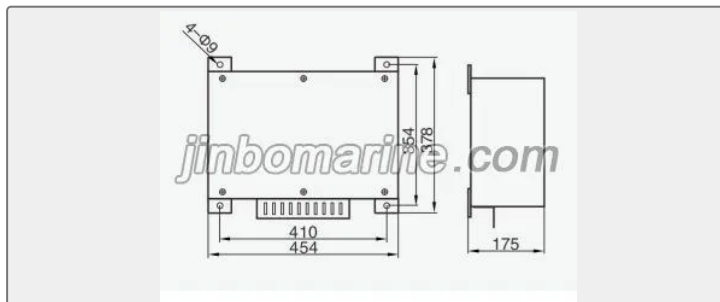

0.077265s

Power:400/600W (DC24V output)

1000W (AC220V output)

Color: Sea gray (B05)

IP class:IP22

Weight:16/20/12Kg

Power:≤500/750W