

Jinbo Marine

Marine & Offshore Equipment Datasheet

PRODUCT DATASHEET

MARINE LED LIGHT

LED JL301 Flood Light

Application Applied to illumination of military ship and ship, decks, dock, plaza and working areas. Product Features 1. The shell is made of high quality stainless steel plate. 2. The lampshade...

ISO9001 Supplier

Class Certificate

Export Supply



Key Highlights

Category	Marine LED Light
Standard	GB
Material	The shell is made of high quality stainless steel plate.
Weight / Size	Specification Type Voltage Power Replacement Liminous Flux CT Weight JL3...
Certificate	ABS, LR, BV, DNVGL, NK, KR, IRS, RMRS, CCS

We can supply according to your requirement, drawings, class certificate needs, and delivery schedule.

Technical Specifications

Category	Marine LED Light	Model / SKU	LED-JL301-Flood-Light
Standard	GB	Material	The shell is made of high quality stainless steel plate.
Weight / Size	Specification Type Voltage Power Replacement Liminous Flux CT Weight JL301 110/220V 50/60HZ 30W 300W Halogen Lamp 2800lm 3000-6500K 3.2kg	Certificate	ABS, LR, BV, DNVGL, NK, KR, IRS, RMRS, CCS
Warranty	12 Months unless specified otherwise	Origin	China

China LED JL301 Flood Light:

Application

Applied to illumination of military ship and ship, decks, dock, plaza and working areas.

Product Features

1. The shell is made of high quality stainless steel plate.
2. The lampshade is made of high-strength toughened glass.
3. LED Light Source, light soft, no glare, supper high uniformity and visual comfort, color \geq 80%, light rate $>$ 70%, life time 30000h,energy saving 50%, new green environmental product, easy installation, general G12 lamp holder.
4. Environment temperature I s -20-45degree within the scope of work.
5. Protection class is IP56.

Standard

1. Chapter 3, Part 4 of Classification Society Rules for Classification of Sea-going Steel Ships 2015 and its Amendments;
- 2.GB7000.1-2015 , Luminaires –Part1:General requirements and tests.

Specification

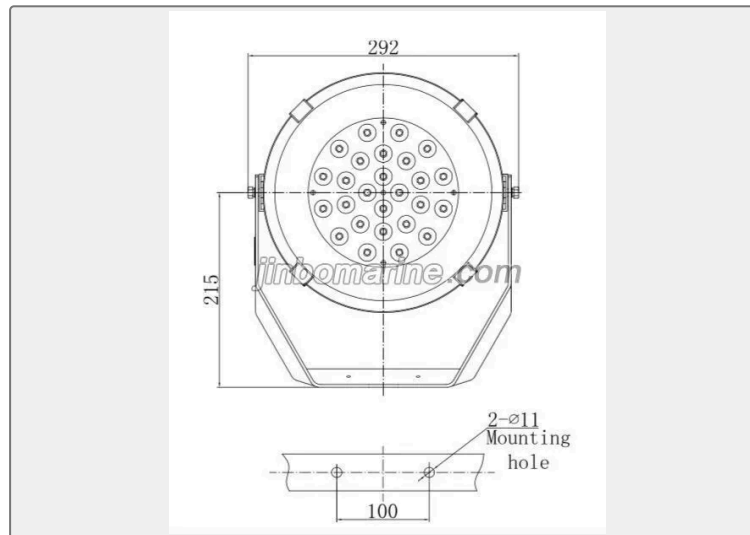

Type	Voltage	Power	Replacement	Luminous Flux	CT	Weight
JL301	110/220V 50/60HZ	30W	300W Halogen Lamp	2800lm	3000-6500K	3.2kg