

Jinbo Marine

Marine & Offshore Equipment Datasheet

PRODUCT DATASHEET

REFRIGERATOR CALL SYSTEM

LJB-1Q Refrigerator Call Main Unit (16way)

ISO9001 Supplier

Class Certificate

Export Supply

LJB-1Q Refrigerator Call Main Unit (16way) 1)Chapter 1 of Part 4 of the"Steel Ship Classification Rules" of the China Classification Society: 2)IMO resolution A.1021 (26) code on alerts and indicators,2009. ...



Key Highlights

Category	Refrigerator Call System
Material	LJB-1Q Refrigerator Call Main Unit (16way) 1)Chapter 1 of Part 4 of the"..."
Certificate	ABS, LR, BV, DNVGL, NK, KR, IRS, RMRS, CCS

We can supply according to your requirement, drawings, class certificate needs, and delivery schedule.

Technical Specifications

Category	Refrigerator Call System	Model / SKU	LJB-1Q-Refrigerator-Call-Main-Unit-16way
Material	LJB-1Q Refrigerator Call Main Unit (16way) 1)Chapter 1 of Part 4 of the"Steel Ship Classification Rules" of the China Classification Society:	Certificate	ABS, LR, BV, DNVGL, NK, KR, IRS, RMRS, CCS
Warranty	12 Months unless specified otherwise	Origin	China

China LJB-1Q Refrigerator Call Main Unit (16way):

LJB-1Q Refrigerator Call Main Unit (16way)

- 1)Chapter 1 of Part 4 of the"Steel Ship Classification Rules" of the China Classification Society:
- 2)IMO resolution A.1021 (26) code on alerts and indicators,2009.



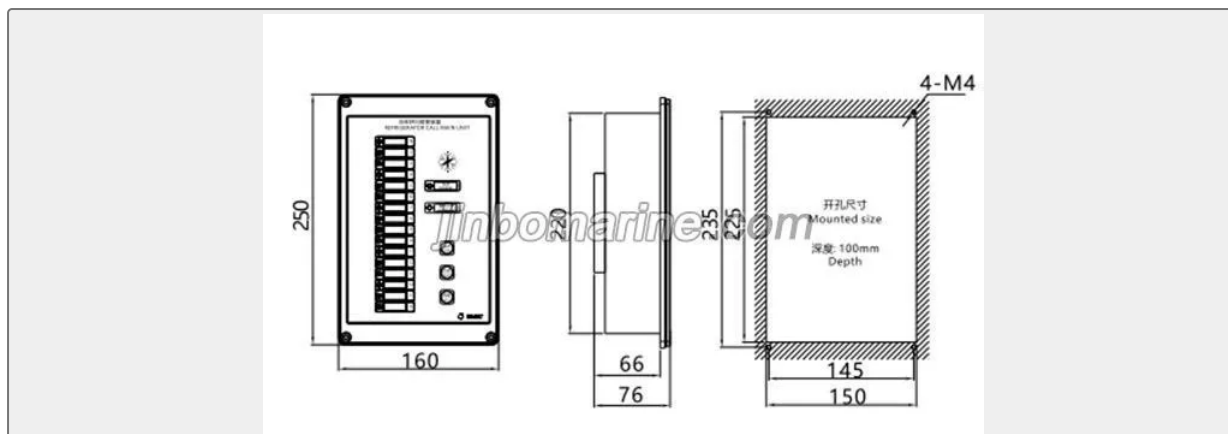

Colour: Dull black

Shell material: ABS

Power supply: DC24V±10%

IP rating: IP20

Power consumption: 50W

Alarm sound pressure level: 75dB~90dB