

MARINE ENGINE TELEGRAPH SYSTEM

# MCL-1AH-Q Receiver Of Marine Main Engine Telegraph

ISO9001 Supplier

Class Certificate

Export Supply

MCL-1AH-Q Receiver Of Marine Main Engine Telegraph 1)Chapter 2 of Part 4 of the"Steel Ship Classification Rules" of the China Classification Society: Colour: Dull black Shell material: ABS ...



### Key Highlights

<b>Category</b>	Marine Engine Telegraph System
<b>Standard</b>	EN
<b>Material</b>	MCL-1AH-Q Receiver Of Marine Main Engine Telegraph 1)Chapter 2 of Part 4...
<b>Certificate</b>	ABS, LR, BV, DNVGL, NK, KR, IRS, RMRS, CCS

We can supply according to your requirement, drawings, class certificate needs, and delivery schedule.

### Technical Specifications

<b>Category</b>	Marine Engine Telegraph System	<b>Model / SKU</b>	MCL-1AH-Q-Receiver-Of-Marine-Main-Engine-Telegraph
<b>Standard</b>	EN	<b>Material</b>	MCL-1AH-Q Receiver Of Marine Main Engine Telegraph 1)Chapter 2 of Part 4 of the"Steel Ship Classification Rules" of the China Classification Society:
<b>Certificate</b>	ABS, LR, BV, DNVGL, NK, KR, IRS, RMRS, CCS	<b>Warranty</b>	12 Months unless specified otherwise
<b>Origin</b>	China		

## China MCL-1AH-Q Receiver Of Marine Main Engine Telegraph:

MCL-1AH-Q Receiver Of Marine Main Engine Telegraph

1)Chapter 2 of Part 4 of the"Steel Ship Classification Rules" of the China Classification Society:



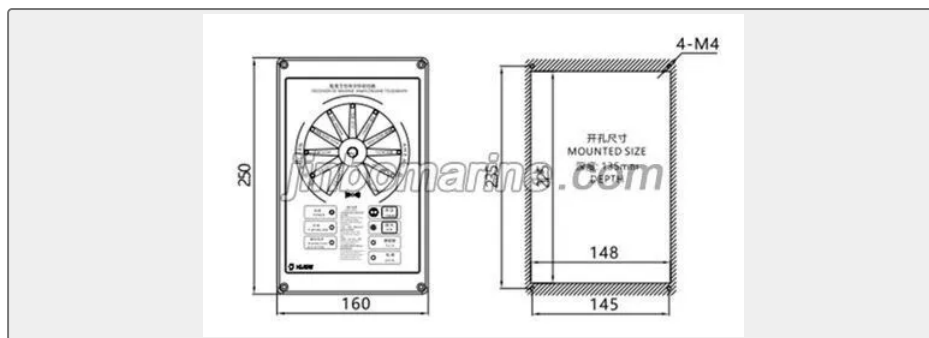

Colour: Dull black

Shell material: ABS

Alarm sound level:  $\geq 75$ dB

IP rating: IP22

When transmitter and receive are not synchronosit will send out wrong-way alarm