

Jinbo Marine

Marine & Offshore Equipment Datasheet

PRODUCT DATASHEET

CENTRIFUGAL PUMP

Marine Ballast Pump PVHB300-15NF

Marine Ballast Pump PVHB300-15NF Marine Ballast Pump PVHB300-15NF as per drawing
Pump Casing: ZCuSn3Zn8Pb6Ni, Impeller: ZCuSn3Z...

ISO9001 Supplier

Class Certificate

Export Supply



Key Highlights

Category	Centrifugal Pump
Certificate	ABS, LR, BV, DNVGL, NK, KR, IRS, RMRS, CCS

We can supply according to your requirement, drawings, class certificate needs, and delivery schedule.

Technical Specifications

Category	Centrifugal Pump	Model / SKU	Marine-Ballast-Pump-PVHB300-15NF
Certificate	ABS, LR, BV, DNVGL, NK, KR, IRS, RMRS, CCS	Warranty	12 Months unless specified otherwise
Origin	China		

China Marine Ballast Pump PVHB300-15NF:

Marine Ballast Pump PVHB300-15NF



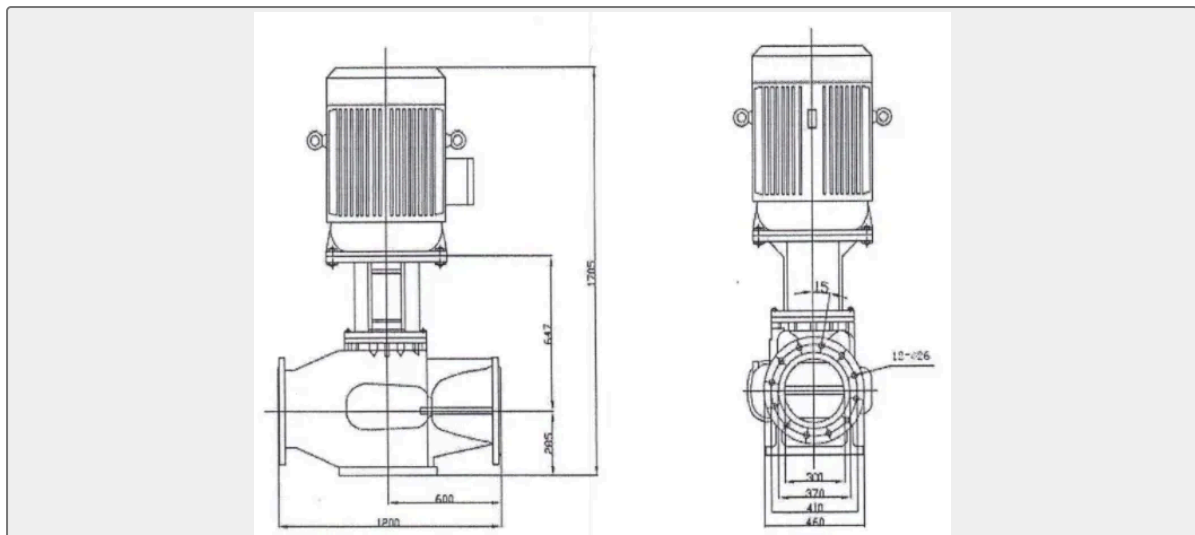

Marine Ballast Pump PVHB300-15NF as per drawing

Pump Casing: ZCuSn3Zn8Pb6Ni,

Impeller: ZCuSn3Zn8Pb6Ni, Shaft: SUS316

Capacity: 1200 m³/h. Head: 8 m.

Speed: 1480r/min, Motor power 55 kW, IP55

Voltage 380V, 50Hz.

Supply CCS Certificate