

Jinbo Marine

Marine & Offshore Equipment Datasheet

PRODUCT DATASHEET

JIS MARINE CHECK VALVE

**Marine Cast Iron Swing Check Valve
JIS F7373 10K**

ISO9001 Supplier

Class Certificate

Export Supply

Design Standard: JIS F7373-1996 Test Standard: JIS 7400-1996 Hydraulic Test Pressure:
Body- 2.1Mpa, Seat-1.54Mpa~0.4Mpa Flange size as per JIS B2220 - 10K Main Material: 1-
Body: Cast Iron (F...

Loading product image...

Key Highlights

| | |
|----------------------|--|
| Category | JIS Marine Check Valve |
| Standard | JIS |
| Material | Cast Iron |
| Weight / Size | Body- 2.1Mpa, Seat- 1.54Mpa~0.4Mpa Flange size as per JIS B2220 - 10K Mai... |
| Certificate | CCS, BV, ABS, GL, LR, DNV, NK,RINA |

We can supply according to your requirement,
drawings, class certificate needs, and delivery
schedule.

Technical Specifications

| | | | |
|----------------------|---|--------------------|--|
| Category | JIS Marine Check Valve | Model / SKU | Marine-Cast-Iron-Swing-Check- Valve-JIS-F7373-10K |
| Standard | JIS | Material | Cast Iron |
| Weight / Size | Body- 2.1Mpa, Seat- 1.54Mpa~0.4Mpa Flange size as per JIS B2220 - 10K Main Material: | Certificate | CCS, BV, ABS, GL, LR, DNV, NK,RINA |
| Warranty | 12 Months unless specified otherwise | Origin | China |

CONTENTS

- China Marine Cast Iron Swing Check Valve JIS F7373 10K:
- Main Material:
- Main Size List(mm):

 0.049895s

China Marine Cast Iron Swing Check Valve JIS F7373 10K:

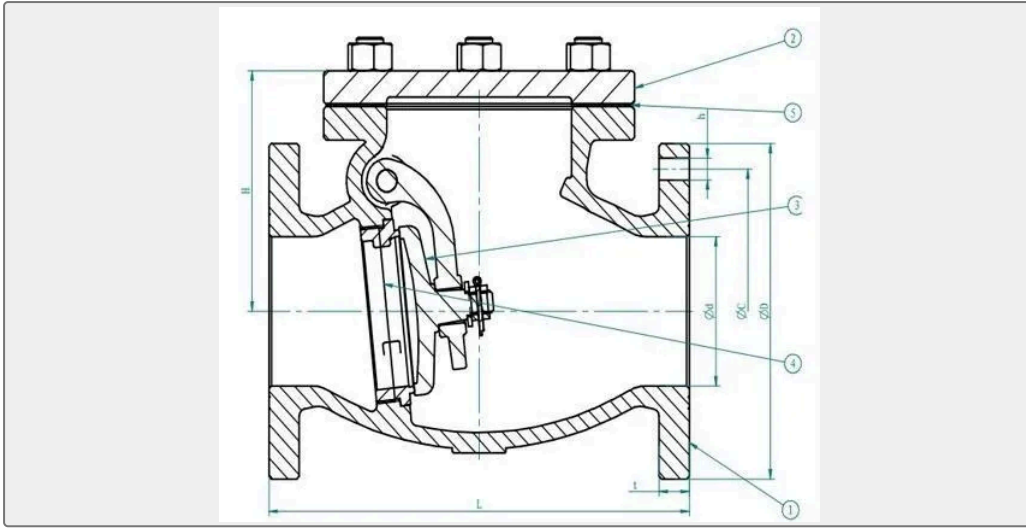

Design Standard: JIS F7373-1996

Test Standard: JIS 7400-1996

Hydraulic Test Pressure: Body- 2.1Mpa, Seat-1.54Mpa~0.4Mpa

Flange size as per JIS B2220 - 10K

Main Material:

1-Body: Cast Iron (FC200)

2-Bonnet: Cast Iron (FC200)

3-Disc: Bronze (BC6) or Stainless Steel

4-Seat: Bronze (BC6) or Stainless Steel

5-Gasket: non-asbestos

Main Size List(mm):

| IMPA Code | Size | L | D | C | t | No of Bolt | h | H |
|-----------|------|-----|-----|-----|----|------------|----|-----|
| 751431 | 50 | 210 | 155 | 120 | 20 | 4 | 19 | 109 |
| 751432 | 65 | 240 | 175 | 140 | 22 | 4 | 19 | 126 |
| 751433 | 80 | 270 | 185 | 150 | 22 | 8 | 19 | 136 |
| 751434 | 100 | 300 | 210 | 175 | 24 | 8 | 19 | 153 |
| 751435 | 125 | 350 | 250 | 210 | 24 | 8 | 23 | 180 |
| 751436 | 150 | 400 | 280 | 240 | 26 | 8 | 23 | 205 |
| 751437 | 200 | 480 | 330 | 290 | 26 | 12 | 23 | 242 |