

Jinbo Marine

Marine & Offshore Equipment Datasheet

PRODUCT DATASHEET

JIS MARINE SIGHT GLASS

Marine Flat Sight Glass JIS F7234 5K

Design Standard: JIS F7234-1995 Test Standard: JIS 7400 Hydraulic Test Pressure: Body- 7.5kgs Flange size as per JIS B2220 - 5K Main Material: 1-Body: Cast Iron (FC200 or FCD400,FCD45...

- ISO9001 Supplier
- Class Certificate
- Export Supply

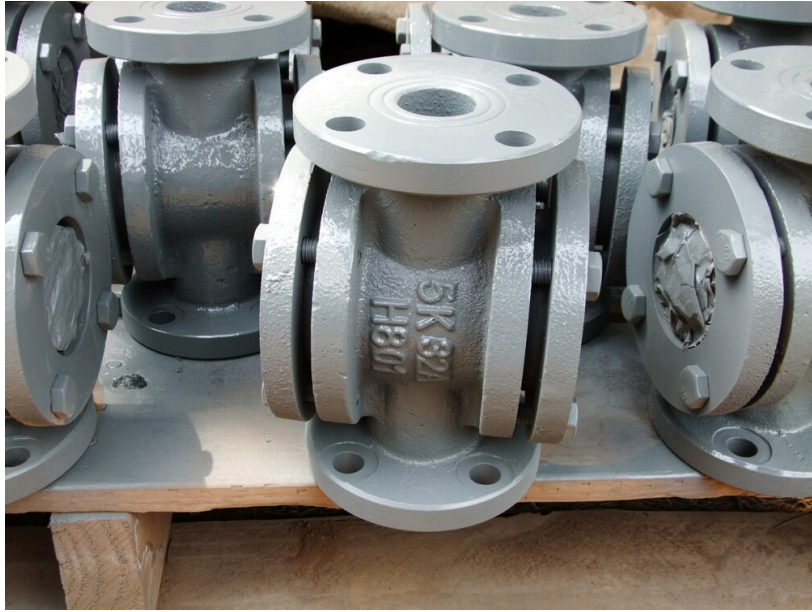

Key Highlights

Category	JIS Marine Sight Glass
Standard	JIS
Material	Cast Iron
Weight / Size	Body- 7.5kgs Flange size as per JIS B2220 - 5K Main Material:
Certificate	CCS,BV, NK,DNV,GL, LR, ABS, RINA

We can supply according to your requirement, drawings, class certificate needs, and delivery schedule.

Technical Specifications

Category	JIS Marine Sight Glass	Model / SKU	Marine-Flat-Sight-Glass-JIS-F7234-5K
Standard	JIS	Material	Cast Iron
Weight / Size	Body- 7.5kgs Flange size as per JIS B2220 - 5K Main Material:	Certificate	CCS,BV, NK,DNV,GL, LR, ABS, RINA
Warranty	12 Months unless specified otherwise	Origin	China

CONTENTS	<ul style="list-style-type: none"> <li style="display: inline-block; width: 45%;">■ China Marine Flat Sight Glass JIS F7234 5K: <li style="display: inline-block; width: 45%;">■ Main Material:
	<ul style="list-style-type: none"> ■ Main Size List(mm):

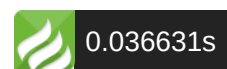

China Marine Flat Sight Glass JIS F7234 5K:

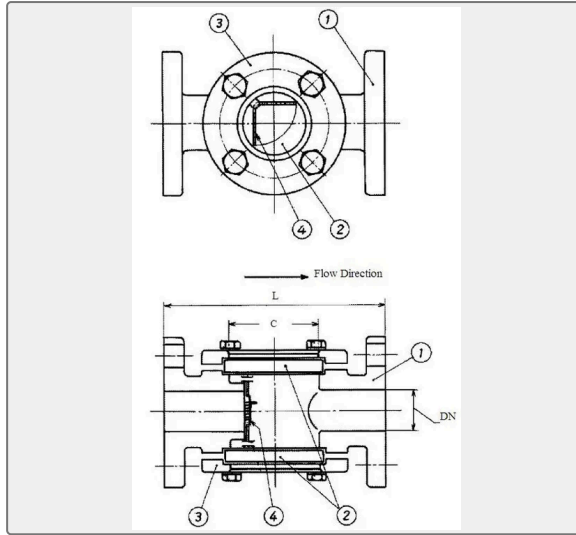

Design Standard: JIS F7234-1995

Test Standard: JIS 7400

Hydraulic Test Pressure: Body- 7.5kgs

Flange size as per JIS B2220 - 5K

Main Material:

1-Body: Cast Iron (FC200 or FCD400,FCD450)

2-Flat Glass: tempered glass

3-Cover: Cast Iron (FC200 or FCD400,FCD450)

4-Flapper: Stainless Steel (SUS304)

Main Size List(mm):

Series		DN								
		15	20	25	32	40	50	65	80	100
Series A	L	150	150	170	200	200	220	250	270	320
	C	40	40	50	70	70	80	100	120	150
Series B	L	140	150	160	200	200	220	250	270	320
	C	40	50	50	60	60	65	80	102	125
Series C	L	150	150	150	180	180	190	240	260	300
	C	42	42	42	62	62	70	105	120	145

