

Jinbo Marine

Marine & Offshore Equipment Datasheet

PRODUCT DATASHEET

MARINE DOOR

Marine Hydraulic Watertight Sliding Door

ISO9001 Supplier

Class Certificate

Export Supply

Accessories of Marine Hydraulic Watertight Sliding Door: Standard: CB/T3007-2000 It is the watertight door for bulkhead below waterline, which is usually used between engine room and shaft tunn...



Key Highlights

Category	Marine Door
Standard	DIN
Material	Steel
Weight / Size	Main Size List(mm):
Certificate	CCS, BV, ABS, GL, LR, DNV, NK,RINA, KR,IRS

We can supply according to your requirement, drawings, class certificate needs, and delivery schedule.

Technical Specifications

Category	Marine Door	Model / SKU	Marine-Hydraulic-Watertight-Sliding-Door
Standard	DIN	Material	Steel
Weight / Size	Main Size List(mm):	Certificate	CCS, BV, ABS, GL, LR, DNV, NK,RINA, KR,IRS
Warranty	12 Months unless specified otherwise	Origin	China

CONTENTS

- China Marine Hydraulic Watertight Sliding Door:
- Component:
- Main Size List(mm):



Marine Hydraulic Watertight Sliding Door Drawing

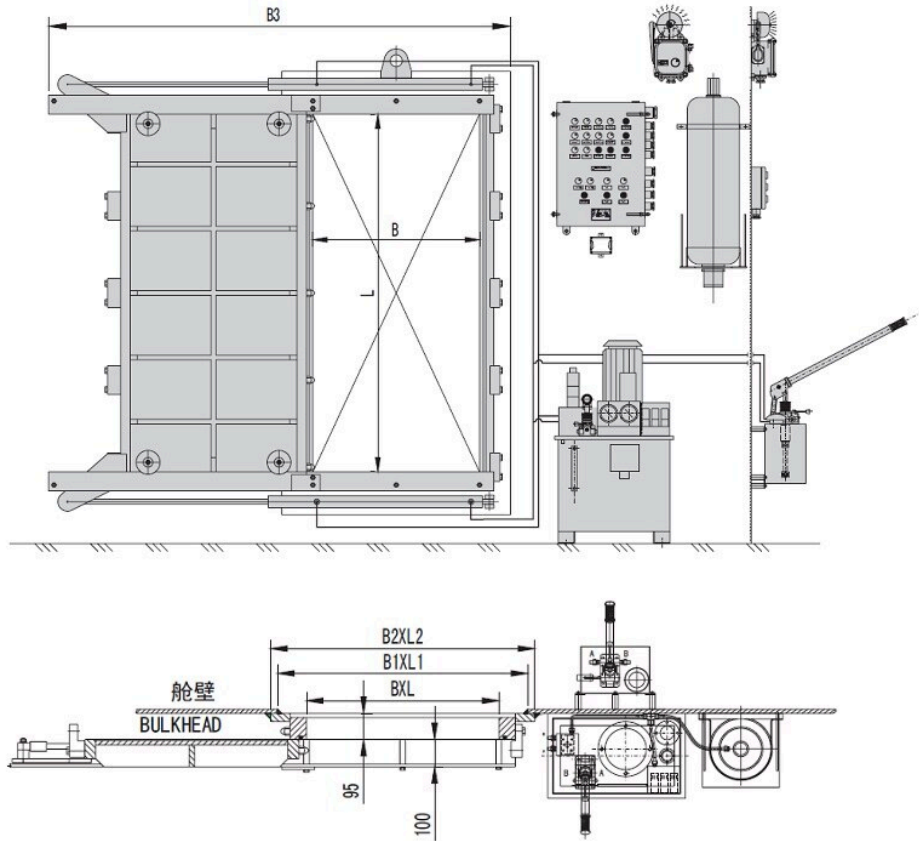

China Marine Hydraulic Watertight Sliding Door:

Accessories of Marine Hydraulic Watertight Sliding Door:



Standard: CB/T3007-2000

It is the watertight door for bulkhead below waterline, which is usually used between engine room and shaft tunnel/boiler room/auxiliary machinery room, etc. It complis with CCS rules. The door can be manually operated mechanically at both sides of engine room, hydraulic operating handle on upper deck also.

*It also can be manufactured with A60 fireproof.

Component:

Watertight door includes three parts ,as the mechanism, hydraulic and electric.

·Mechanism part includes door frame, door plate, guide roller and cylinder bracket.

·Hydraulic part consists of hydraulic pump unit (including motor, oil pump, electromagnetism change valve ,throttle, overflow valve, one way valve, level switch, high-low pressure relay, low pressure relay, level controller etc),oil cylinder, hand pump, hand change valve, accumulator and pressure gauge etc.

·Electric part consists of start-up alarm box, alarm lamp and bell (combination type),limit switch and button box etc.

Main Size List(mm):

Doorway Size	Opening Size	Frame Size	B3	Opening Direction
BXL	B1XL1	B2XL2		
600X1000	800X1200	860X1360	1740	Left, Right
600X1200	800X1400	860X1560	1740	
600X1400	800X1600	860X1760	1740	
700X1200	900X1400	960X1560	1940	
700X1400	900X1600	960X1760	1940	
700X1500	900X1700	960X1860	1940	