

# Jinbo Marine

Marine &amp; Offshore Equipment Datasheet

PRODUCT DATASHEET

## MARINE VENTILATOR

## Marine Mushroom Ventilator Type B

Standard: CB/T295-2000 The marine mushroom ventilator is installed on the natural & mechanical ventilation device on the exposed deck of all sorts of ships. The feature is with reasonable structure, convenient ...

ISO9001 Supplier

Class Certificate

Export Supply



### Key Highlights

Category	Marine Ventilator
Standard	CB
Material	Steel
Weight / Size	1-Handwheel 2- Hood 3-Screw Stem 4-Seal 5-Weathertight cover 6-mouse pro...
Certificate	CCS, BV, ABS, GL, LR, DNV, NK,RINA, KR,IRS

We can supply according to your requirement, drawings, class certificate needs, and delivery schedule.

### Technical Specifications

Category	Marine Ventilator	Model / SKU	Marine-Mushroom-Ventilator-Type-B
Standard	CB	Material	Steel
Weight / Size	1-Handwheel 2- Hood 3-Screw Stem 4-Seal 5-Weathertight cover 6-mouse proof,insect prevention screen or fireproof screen 7-Ventilator 8-Instruction stick 9-Casing Pipe 10-Oil Cup Main Size List for Type B(mm):	Certificate	CCS, BV, ABS, GL, LR, DNV, NK,RINA, KR,IRS
Warranty	12 Months unless specified otherwise	Origin	China

#### CONTENTS

- China Marine Mushroom Ventilator Type B:
- Main Parts:
- Main Types:
- Main Size List for Type B(mm):



0.053029s

# China Marine Mushroom Ventilator Type B:

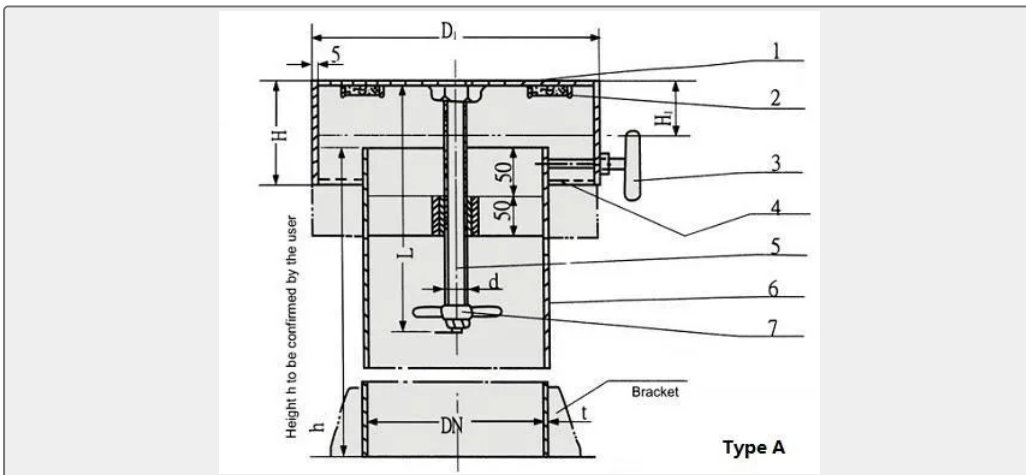

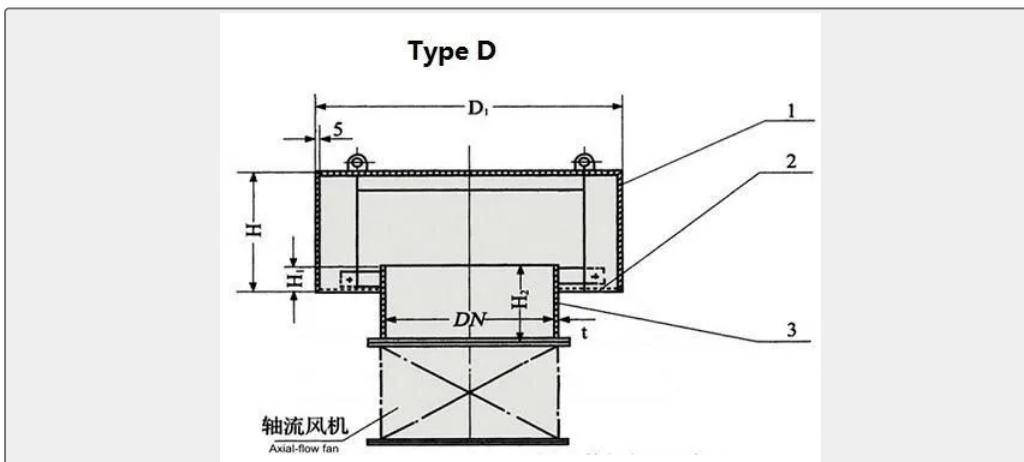
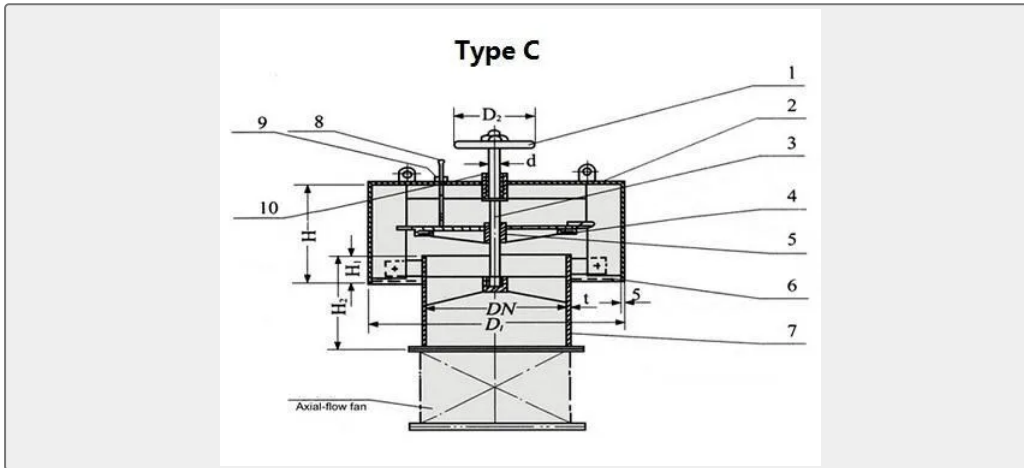
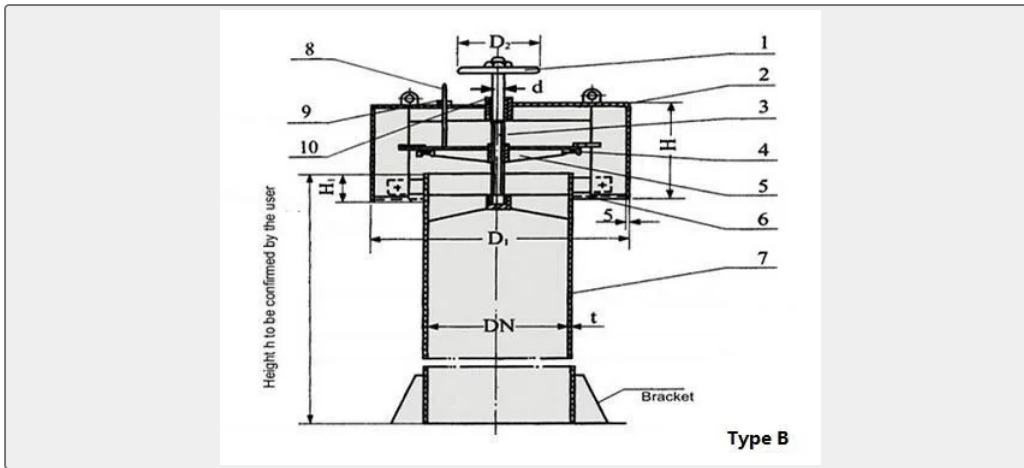

Standard: CB/T295-2000

The marine mushroom ventilator is installed on the natural & mechanical ventilation device on the exposed deck of all sorts of ships. The feature is with reasonable structure, convenient opening & closing, weathertight.

\*For Type B, when the h is over 900mm, it should be with the bracket.

## Main Types:

Type A-Inside opening & closing Mushroom Ventilator

Type B-Outside opening & closing weathertight t Mushroom Ventilator (Welded installment)

Type C-Outside opening & closing weathertight Mushroom Ventilator (Bolted installment)

Type D-Fixed ventilator



## Main Parts:

- 1-Handwheel
- 2- Hood
- 3-Screw Stem
- 4-Seal
- 5-Weathertight cover
- 6-mouse proof,insect prevention screen or fireproof screen
- 7-Ventilator
- 8-Instruction stick
- 9-Casing Pipe
- 10-Oil Cup

## Main Size List for Type B(mm):

Nominal Dia. ( DN)	D1.	D2	H	H1	H2	d	t	weight(kgs)
250	440	200	220	90	210	Tr24*5-LH	9	52
300	530		265					65
350	620		310			81		Tr30*6-LH

400	710	280	345	105	230	Tr40*7-LH	10	98
450	800		375					124
500	890	320	405					148
550	980		435					167
600	1050		470	120	270			171
650	1160		500					210
700	1240		520					225
750	1320		540					259
800	1410		560	140	320			291
850	1500		580					322
900	1580	360	600			Tr46*8-LH		357
950	1670		620					387
1000	1760		640					420
1100	1930		680					515
1200	2100		720					585
1300	2270		760					659
1400	2440	400	800		350			674