

Jinbo Marine

Marine & Offshore Equipment Datasheet

PRODUCT DATASHEET

MARINE AIR CONDITIONER

NCBH Marine Explosion Proof Heater Air Fan

ISO9001 Supplier

Class Certificate

Export Supply

Description: NCBH Marine explosion-proof heater The Marine anti-explosion fan heater of NCBH apply to the heating system of ship and the anti-explosion chemical environment. The fan heating adopts anti-expl...



Key Highlights

Category	Marine Air Conditioner
Standard	CB
Weight / Size	Type Heating Medium Heat supply quantity KW Air volume (m3/h) Outlet tem...
Certificate	ABS, LR, BV, DNVGL, NK, KR, IRS, RMRS, CCS

We can supply according to your requirement, drawings, class certificate needs, and delivery schedule.

Technical Specifications			
Category	Marine Air Conditioner	Model / SKU	NCBH-Marine-Explosion-Proof-Heater-Air-Fan
Standard	CB	Weight / Size	Type Heating Medium Heat supply quantity KW Air volume (m3/h) Outlet temperature °C Inlet Temperature °C Outlet velocity m/s Noise dB(A) Motor power (kw) Weight (kg) NCBH-30 0.4MPa steam 43 2500 66 15 3 58 1400 54 hotwater 22 41 NCBH-60 0.4MPa steam 75 5000 60 15 3.6 69 1390 97 hotwater 32 34 NCBH-90 0.4MPa steam 126 7100 66 15 3.3 75 910 126 hotwater 53 36 NCBH-125 0.4MPa steam 255 10000 80 15 3.3 70 940 212 hotwater 71 43 Dimension:
Certificate	ABS, LR, BV, DNVGL, NK, KR, IRS, RMRS, CCS	Warranty	12 Months unless specified otherwise
Origin	China		

CONTENTS	Description:	Technical Data:
	Dimension:	

Description:

NCBH Marine explosion-proof heater

The Marine anti-explosion fan heater of NCBH apply to the heating system of ship and the anti-explosion chemical environment. The fan heating adopts anti-explosion motor AC 380V/440V 3P 50/60Hz.

Technical Data:

Type	Heating Medium	Heat supply quantity KW	Air volume (m3/h)	Outlet temperature °C	Inlet Temperature °C	Outlet velocity m/s	Noise dB(A)	Motor power (kw)	Weight (kg)
NCBH-30	0.4MPa steam	43	2500	66	15	3	58	1400	54
hotwater	22	41							

NCBH-60	0.4MPa steam	75	5000	60	15	3.6	69	1390	97
hotwater	32	34							
NCBH-90	0.4MPa steam	126	7100	66	15	3.3	75	910	126
hotwater	53	36							
NCBH-125	0.4MPa steam	255	10000	80	15	3.3	70	940	212
hotwater	71	43							

Dimension:

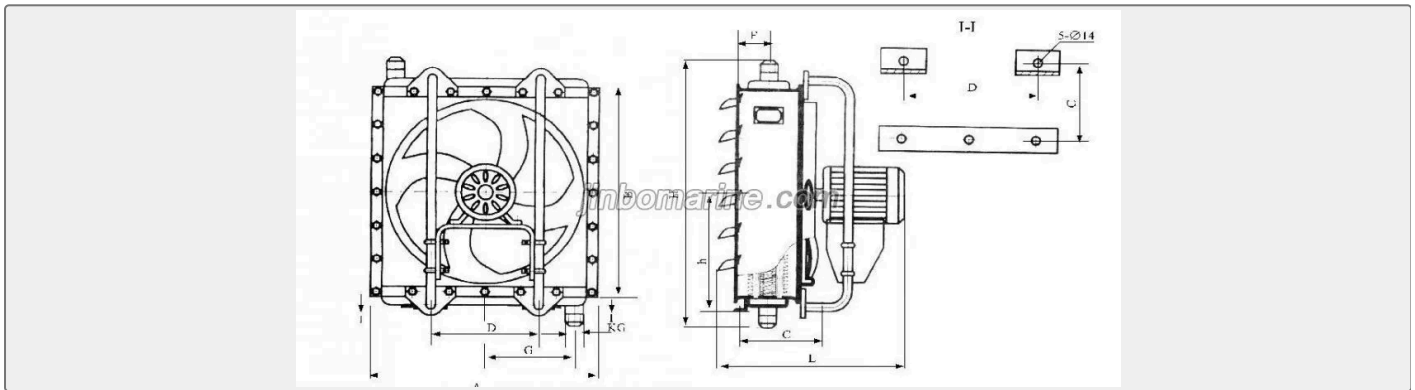

Type	A	B	D	F	G	H	h	l	Φ
NCBH-30	533	540	248	128.5	203	680	295	550	400
NCBH-60	689	696	312	128.5	267	836	382	667	600
NCBH-90	845	852	370	128.5	345	992	451	690	700
NCBH-125	1020	1010	440	156	420	1152	535	830	800