

Jinbo Marine

Marine & Offshore Equipment Datasheet

PRODUCT DATASHEET

HIGH HOLDING POWER ANCHOR

Type TW Anchor

Type TW Anchor (Type Anchor, TW Anchor) TW Anchor(Anchor, TW Type) is also an High Holding Power Anchor, holding-power-to-weight is about 6, anchor flukes are smooth and sharp, suitable for all soil condi...

ISO9001 Supplier

Class Certificate

Export Supply



Key Highlights

Category	High Holding Power Anchor
Standard	DIN
Material	Casting Steel
Weight / Size	20KGS to 30000KGS
Certificate	ABS, LR, BV, DNV, GL, RINA, NK, KR, RS, IRS, CCS

We can supply according to your requirement, drawings, class certificate needs, and delivery schedule.

Technical Specifications

Category	High Holding Power Anchor	Model / SKU	POOL-TW-Anchor
Standard	DIN	Material	Casting Steel
Weight / Size	20KGS to 30000KGS	Certificate	ABS, LR, BV, DNV, GL, RINA, NK, KR, RS, IRS, CCS
Warranty	12 Months unless specified otherwise	Origin	China

CONTENTS

- China Type TW Anchor:
- Dimension Table:
- Technical Spec:

China Type TW Anchor:

Type TW Anchor (Type Anchor, TW Anchor)

TW Anchor(Anchor, TW Type) is also an High Holding Power Anchor, holding-power-to-weight is about 6, anchor flukes are smooth and sharp, suitable for all soil conditions, drop and weigh anchor is convenient, commonly used as Bow Anchor or Offdrill Anchor.



All anchors could be supplied with Classification Certificate, LR, ABS, BV, GL, DNV, KR, NK, IRS and CCS Certificate.

Technical Spec:

Material: Casting Steel

Weight: 20KGS to 30000KGS

Class Certificate: LR, ABS, BV, GL, DNV, KR, NK, IRS and CCS

Dimension Table:

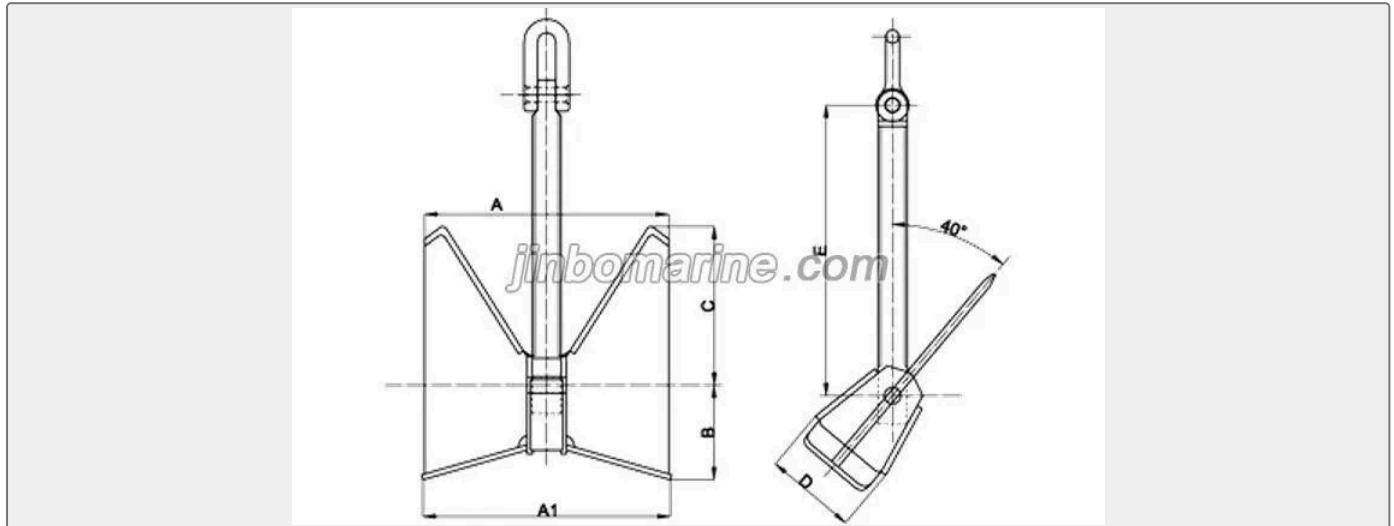

Nominal Weight (KG)	Size(mm)					
	A	B	C	D	E	F
20	369	374	144	240	136	402
32	435	437	168	280	158	469
40	469	476	183	305	172	510
60	536	544	210	349	197	585
75	578	587	225	376	212	630
80	600	610	225	400	222	685
90	615	624	240	400	226	670
105	648	658	252	422	240	710
125	686	694	267	447	254	750
135	705	716	274	459	261	773
145	720	730	280	470	266	788
160	746	758	290	486	276	818
180	776	787	301	505	287	850
225	836	848	325	544	309	0.039318s

270	888	902	342	573	326	965
300	920	933	357	598	340	1008
360	978	993	380	637	362	1072
400	996	1010	386	648	374	1090
450	1038	1053	403	675	390	1137
490	1086	1103	422	707	402	1190
565	1136	1153	425	740	420	1245
582	1160	1180	450	755	428	1270
675	1205	1224	468	785	446	1322
765	1257	1276	488	818	465	1378
855	1286	1306	500	841	480	1411
1000	1360	1380	528	885	503	1480
1080	1400	1420	542	915	520	1530
1130	1410	1430	547	917	521	1544
1195	1458	1479	566	949	540	1597
1305	1486	1509	579	973	556	1634
1440	1535	1560	596	1001	578	1683
1575	1584	1608	615	1032	596	1735
1710	1628	1651	632	1060	612	1782
1845	1670	1695	648	1084	628	1828
1980	1704	1731	667	1119	638	1880
2140	1754	1768	676	1135	655	1908
2295	1795	1822	697	1169	675	1966
2475	1741	1868	715	1199	692	2016
2665	1886	1912	732	1228	708	22064
2750	1907	1930	738	1238	715	2082
2835	1926	1955	748	1255	725	2110
3000	1972	2002	765	1285	742	2160
3240	2014	2044	782	1311	757	2205
3445	2056	2087	798	1340	774	2258
3690	2100	2130	815	1367	790	2298
3940	2150	2182	834	1400	808	2354
4210	2198	2230	853	1431	826	2400

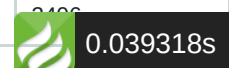

4500	2236	2271	870	1462	836	2454
4840	2302	2336	894	1499	865	2520
5175	2318	2355	914	1555	868	2596
5250	2366	2400	918	1540	890	2590
5515	2405	2440	933	1566	905	2634
5850	2453	2489	952	1598	922	2685
6225	2504	2542	972	1632	942	2743
6525	2550	2580	987	1658	956	2807
6975	2600	2640	1010	1695	978	2849
7875	2695	2735	1050	1773	1012	2980
8325	2757	2784	1070	1806	1041	3035
8775	2797	2825	1089	1830	1056	3074
9225	2865	2894	1108	1858	1073	3121
9675	2905	2934	1126	1888	1090	2172
10125	2491	2970	1143	1918	1108	3223
10575	2979	3009	1160	1946	1124	3270
11025	3027	3057	1176	1974	1140	3317
12075	3121	3152	1212	2034	1175	3418
12675	3160	3192	1230	2064	1192	3468
13350	3221	3253	1254	2104	1215	3535
14100	3295	3328	1276	2142	1237	3600
15000	3357	3380	1294	2166	1262	3640
16125	3443	3470	1326	2219	1293	3728
20000	3690	3727	1429	2399	1385	4030
25000	3986	4026	1544	2590	1496	4354
30000	4237	4270	1640	2754	1590	4626

TW Anchor Sea Shipment

All anchor lashed and fixed in the container in order to avoid to make damage on the container.



Fast Delivery(Incotems 2010)

Please feel free to contact us if you have inquiry or RFQ.