

Jinbo Marine

Marine & Offshore Equipment Datasheet

PRODUCT DATASHEET

CENTRIFUGAL PUMP

PVHB150-80AY 300m3 per Hour Marine Vertical Centrifugal Ballast Water Emergency

ISO9001 Supplier

Class Certificate

Export Supply

PVHB300-25ACM 300m3 per Hour Marine Vertical Centrifugal Ballast Water Emergency Fire Pump MODEL PVHB150-80AY CAPACITY 3...



Key Highlights

Category	Centrifugal Pump
Standard	EN
Certificate	ABS, LR, BV, DNVGL, NK, KR, IRS, RMRS, CCS

We can supply according to your requirement, drawings, class certificate needs, and delivery schedule.

Technical Specifications

Category	Centrifugal Pump	Model / SKU	PVHB150-80AY-300m3-per-Hour-Marine-Vertical-Centrifugal-Ballast-Water-Emergency
Standard	EN	Certificate	ABS, LR, BV, DNVGL, NK, KR, IRS, RMRS, CCS
Warranty	12 Months unless specified otherwise	Origin	China



PVHB300-25ACM 300m3 per Hour Marine Vertical Centrifugal Ballast Water Emergency Fire Pump

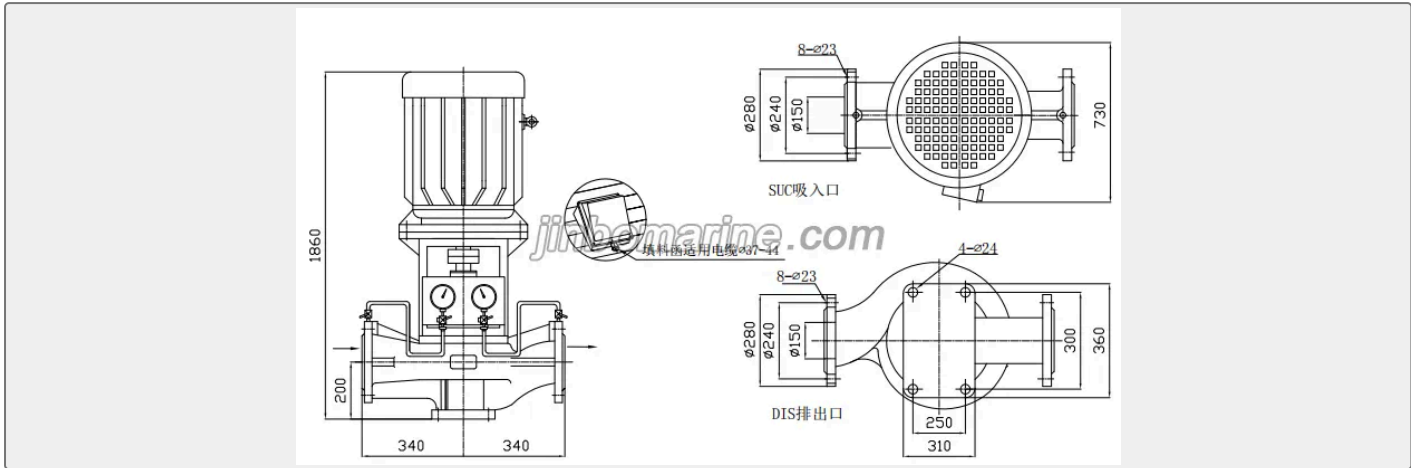

MODEL	PVHB150-80AY
CAPACITY	300M3/h
TOTAL HEAD	10m
Suction Height	-7m
SPEED	3500r/min
FEEDWATER TEMP	120°C
POWER REQUIRED	110KW
Seal	Mechanical Seal
Protection class	IP54 F
Power	440V 60Hz 3P