

Jinbo Marine

Marine & Offshore Equipment Datasheet

PRODUCT DATASHEET

DIAPHRAGM PUMP

QBY Series Pneumatic Diaphragm Pump

ISO9001 Supplier

Class Certificate

Export Supply

QBY series pneumatic diaphragm pump General description QBY pneumatic diaphragm pump is a new type of conveying machinery, Is the current domestic one of the most innovative pump, Using air compressor ...



Key Highlights

Category	Diaphragm Pump
Standard	ISO
Material	Aluminum alloy, cast iron, stainless steel
Weight / Size	air consumption Q(m ³ /h) (M) kgf/cm ² (mm) (kbf/cm ²) (m ³ /min) QBY-10 0~0.8... 0.3 QBY-15 0~1.5 6 1 7 0.3 QBY-25 0~2.4 7 6 2.5 7 0.6 QBY-40 0~8 7 6 4.5 7 0.6 QBY-50 0~12 7 6 8 7 0.9 QBY-65 0~16 7 6 8 7 0.9 QBY-80 0~24 7 6 10 7 1.5 QBY-100 0~30 7 6 10 7 1.5
Certificate	CCS

We can supply according to your requirement, drawings, class certificate needs, and delivery schedule.

Technical Specifications

Category	Diaphragm Pump	Model / SKU	QBY-Series-Pneumatic-Diaphragm-Pump
Standard	ISO	Material	Aluminum alloy, cast iron, stainless steel
Weight / Size	air consumption Q(m ³ /h) (M) kgf/cm ² (mm) (kbf/cm ²) (m ³ /min) QBY-10 0~0.8 5 6 1 7 0.3 QBY-15 0~1.5 6 1 7 0.3 QBY-25 0~2.4 7 6 2.5 7 0.6 QBY-40 0~8 7 6 4.5 7 0.6 QBY-50 0~12 7 6 8 7 0.9 QBY-65 0~16 7 6 8 7 0.9 QBY-80 0~24 7 6 10 7 1.5 QBY-100 0~30 7 6 10 7 1.5	Certificate	CCS
Warranty	12 Months unless specified otherwise	Origin	China



0.044578s

CONTENTS

- QBY series pneumatic diaphragm pump
 - The main features
 - Performance parameter
- General description
 - Structural Specifications

QBY series pneumatic diaphragm pump

General description

QBY pneumatic diaphragm pump is a new type of conveying machinery, Is the current domestic one of the most innovative pump, Using air compressor compressed air as power source, For all kinds of corrosive liquid With particles of liquid, high viscosity, volatile, flammable, poisonous liquid, All can be smoked light. A total of eight kinds of specifications of diameter, $\text{¢}10\text{mm}(3/8\text{'})$ 、 $\text{¢}15\text{mm}(1/2\text{'})$ 、 $\text{¢}25\text{mm}(1\text{'})$ 、 $\text{¢}40\text{mm}(1\ 1/2\text{'})$ 、 $\text{¢}50\text{mm}(2\text{'})$ 、 $\text{¢}65\text{mm}(2\ 1/2\text{'})$ 、 $\text{¢}80\text{mm}(3\text{'})$ 、 $\text{¢}100\text{mm}(4\text{'})$ three kinds of material:Aluminum alloy,cast iron,stainless steel.QBY pneumatic diaphragm pump according to different liquid medium with nitrile butadiene rubber, chloroprene rubber, fluorine rubber, Teflon. To meet the needs of different users

The main features

Flow and spacious, with good performance,The allowed maximum particle diameter by 10 mm When pumping mud and impurities The pump wear little Head and flow rate can be adjusted by the valve opening Will not cause environmental pollution and harm the personal safety

Structural Specifications

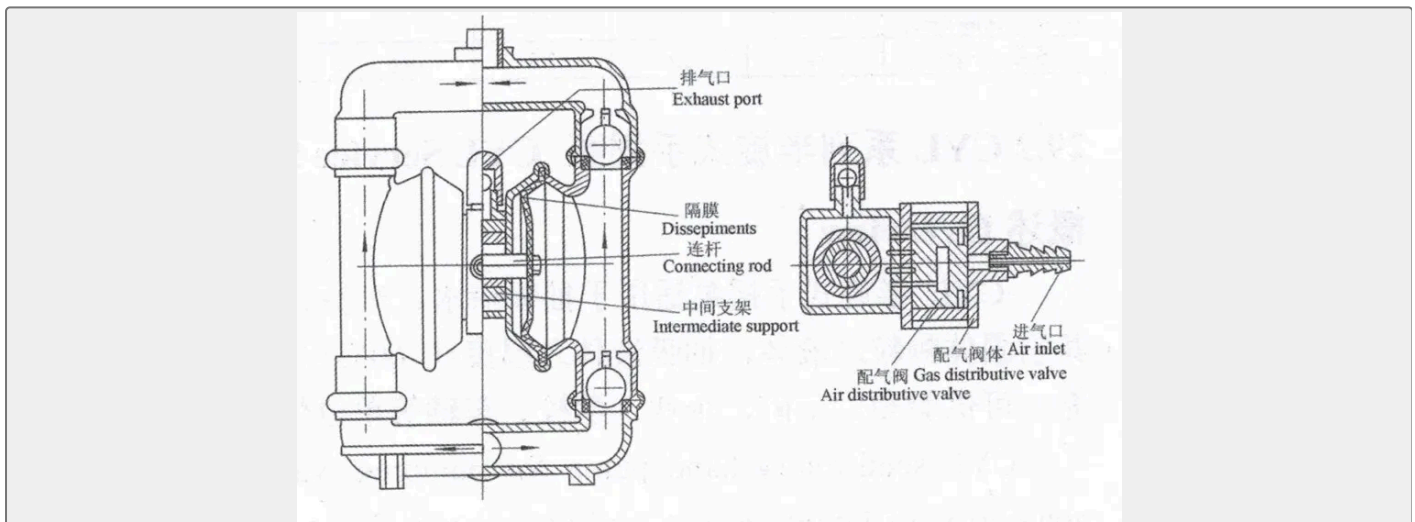

Performance parameter

Model	flow rate	suc' head	Pressure	Max Diameter	max air supply pressure	Max. air consumption
Q(m ³ /h)	(M)	kgf/cm ²	(mm)	(kbf/cm ²)	(m ³ /min)	
QBY-10	0~0.8	5	6	1	7	0.3
QBY-15	0~1	5	6	1	7	0.3
QBY-25	0~2.4	7	6	2.5	7	0.6
QBY-40	0~8	7	6	4.5	7	0.6



QBY-50	0~12	7	6	8	7	0.9
QBY-65	0~16	7	6	8	7	0.9
QBY-80	0~24	7	6	10	7	1.5
QBY-100	0~30	7	6	10	7	1.5