

Jinbo Marine

Marine & Offshore Equipment Datasheet

PRODUCT DATASHEET

MARINE KITCHEN GALLEY

QHZ100-2 Marine Fuel Oil Vaporization Stove

ISO9001 Supplier

Class Certificate

Export Supply

QHZ100-2 Marine Fuel Oil Vaporization Stove 1. All stainless steel structure 2. Adopt safe electronic igniter for easy operation 3. The body has a pressure tank 4. Set up handrails for wave protection 5. The ba...



Key Highlights

Category	Marine Kitchen Galley
Material	SS
Weight / Size	The base form is suitable for installation and fixing on ships QHZ100-2 ...
Certificate	ABS, LR, BV, DNVGL, NK, KR, IRS, RMRS, CCS

We can supply according to your requirement, drawings, class certificate needs, and delivery schedule.

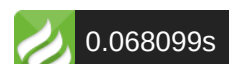

Technical Specifications			
Category	Marine Kitchen Galley	Model / SKU	QHZ100-2-Marine-Fuel-Oil-Vaporization-Stove
Material	SS	Weight / Size	The base form is suitable for installation and fixing on ships QHZ100-2 Marine Fuel Oil Vaporization Stove Drawing QHZ100-2 Marine Fuel Oil Vaporization Stove Parameters Model QHZ50-2 QH100-2 QHZ200-2 Fuel Consumption 2.5-2.8kg/h 2.5-2.8kg/h 4-4.6kg/h Voltage 220v-1PH-50Hz Power(kw) 0.3 0.3 0.3 Size(mm) 1245x645x850 1650x850x850 1840x940x850 Weight(kg) 100 130 150
Certificate	ABS, LR, BV, DNVGL, NK, KR, IRS, RMRS, CCS	Warranty	12 Months unless specified otherwise
Origin	China		

CONTENTS	
<ul style="list-style-type: none"> ■ QHZ100-2 Marine Fuel Oil Vaporization Stove ■ QHZ100-2 Marine Fuel Oil Vaporization Stove Parameters 	<ul style="list-style-type: none"> ■ QHZ100-2 Marine Fuel Oil Vaporization Stove Drawing

QHZ100-2 Marine Fuel Oil Vaporization Stove

1. All stainless steel structure
2. Adopt safe electronic igniter for easy operation
3. The body has a pressure tank
4. Set up handrails for wave protection
5. The base form is suitable for installation and fixing on ships

QHZ100-2 Marine Fuel Oil Vaporization Stove Drawing

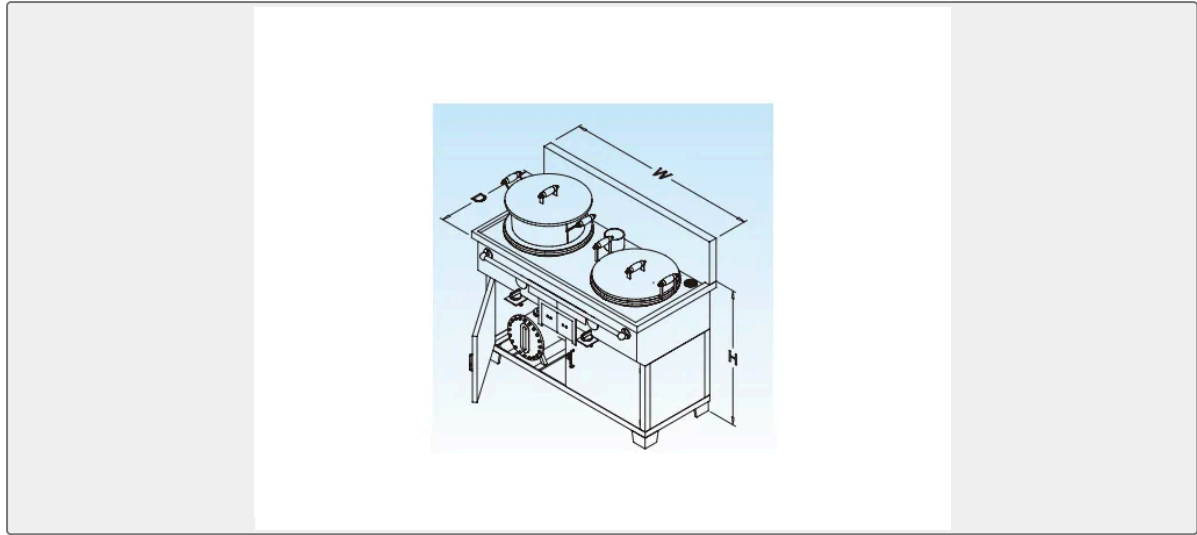

QHZ100-2 Marine Fuel Oil Vaporization Stove Parameters

Model	QHZ50-2	QH100-2	QHZ200-2
Fuel Consumption	2.5-2.8kh/h	2.5-2.8kg/h	4-4.6kg/h
Voltage	220v-1PH-50Hz		
Power(kw)	0.3	0.3	0.3
Size(mm)	1245x645x850	1650x850x850	1840x940x850
Weight(kg)	100	130	150