

Technical Specifications			
Category	Sewage Pump	Model / SKU	QYW25-45-Type-Pneumatic-Submersible-Drainage-pump
Standard	EN	Material	Cast iron pump cast, Bronze impeller, Stainless steel pump shaft
Weight / Size	QYW25-45 Type Pneumatic Submersible Drainage pump General In the new QYQ17-70 type air compressor is designed based on the QYW25-45 type pneumatic submersible drainage pump, beautiful appearance, small volume, light weight, large flow, flow of the use of type structure, semi-open impeller for use HT200 material, can be less than or equal to 14mm particles, drainage capability, not because of the small solid particles or fibers inhalation and block, not due to abrasive medium inhalation and premature failure.	Surface	The pump is of simple overall structure, convenient assembly and disassembly and maintenance in mobile, with fire damper and coal dust surface using the absolute safety is reliable, and the exhaust port is equipped with advanced new muffler, greatly reduces the noise measured, which can be used for coal mine in ship operations and stripping etc.
Certificate	CCS	Warranty	12 Months unless specified otherwise
Origin	China		

CONTENTS	■ QYW25-45 Type Pneumatic Submersible Drainage pump	■ Model Explanation QYW25-45
	■ Structural Specifications	■ Performance Parameter (380v/50hz)

QYW25-45 Type Pneumatic Submersible Drainage pump

General

In the new QYQ17-70 type air compressor is designed based on the QYW25-45 type pneumatic submersible drainage pump, beautiful appearance, small volume, light weight, large flow, flow of the use of type structure, semi-open impeller for use HT200 material, can be less than or equal to 14mm particles, drainage capability, not because of the small solid particles or fibers inhalation and block, not due to abrasive medium inhalation and premature failure. The pump is of simple overall structure, convenient assembly and disassembly and maintenance in mobile, with fire damper and coal dust surface using the absolute safety is reliable, and the exhaust port is equipped with advanced new muffler, greatly reduces the noise measured, which can be used for coal mine in ship operations and stripping etc.

Model Explanation QYW25-45

- QY-Pneumatic vane motor



- W-Submersible drainage pump
- 25-Flow rate 25m³/h
- 45-Head 45m

Structural Specifications

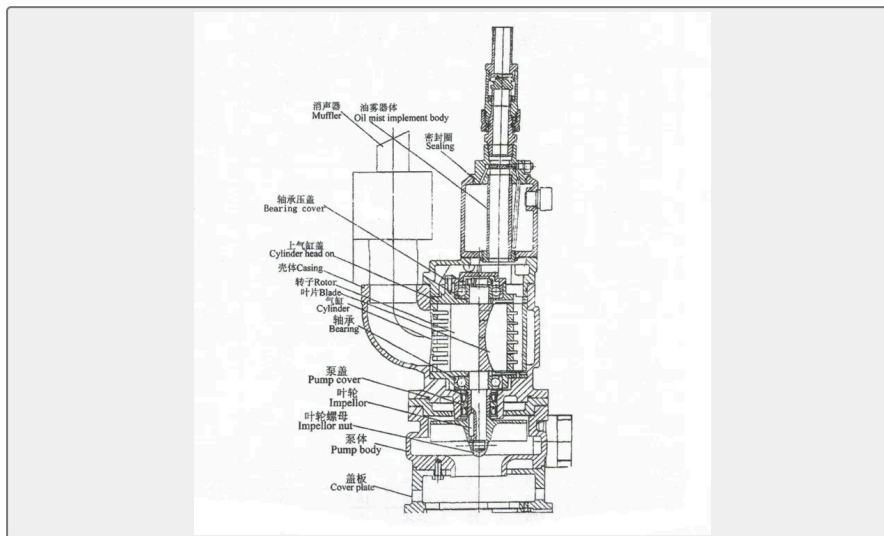

Performance Parameter (380v/50hz)

型号 Type	流量 Capacity (m ³ /h)	扬程 Head (m)	使用风压 Use wind pressure (Mpa)	耗气量 Gas consumption (m ³ /min)	耗油量 Fuel consumption (ml/h)	重量 Weight (kg)	转速 Speed (rpm)	外形尺寸 Shape dimension (L×W×H)(mm)
QYW25-45	25~38	45~10	0.4~0.7	5~6	50	31	3500~4000	350×200×500