

Jinbo Marine

Marine & Offshore Equipment Datasheet

PRODUCT DATASHEET

STUD LINK MOORING CHAIN

R5 Offshore Stud Link Mooring Chain

R5 Offshore Stud Link Mooring Chain is highest grade mooring chain for mooring system, with good performance in the sea water. This chains has been introduced for the higher requirement in the oil and gas offshore ...

ISO9001 Supplier

Class Certificate

Export Supply



Key Highlights

Category	Stud Link Mooring Chain
Standard	EN
Material	Rolled Steel Bars
Weight / Size	Size:
Certificate	ABS, LR, BV, GL, RINA, DNV, NK, KR, CCS

We can supply according to your requirement, drawings, class certificate needs, and delivery schedule.

Technical Specifications

Category	Stud Link Mooring Chain	Model / SKU	R5-Offshore-Stud-Link-Mooring-Chain
Standard	EN	Material	Rolled Steel Bars
Weight / Size	Size:	Surface	Painted
Certificate	ABS, LR, BV, GL, RINA, DNV, NK, KR, CCS	Warranty	12 Months unless specified otherwise
Origin	China		

CONTENTS

- China R5 Offshore Stud Link Mooring Chain:

- Main Specification:



China R5 Offshore Stud Link Mooring Chain:

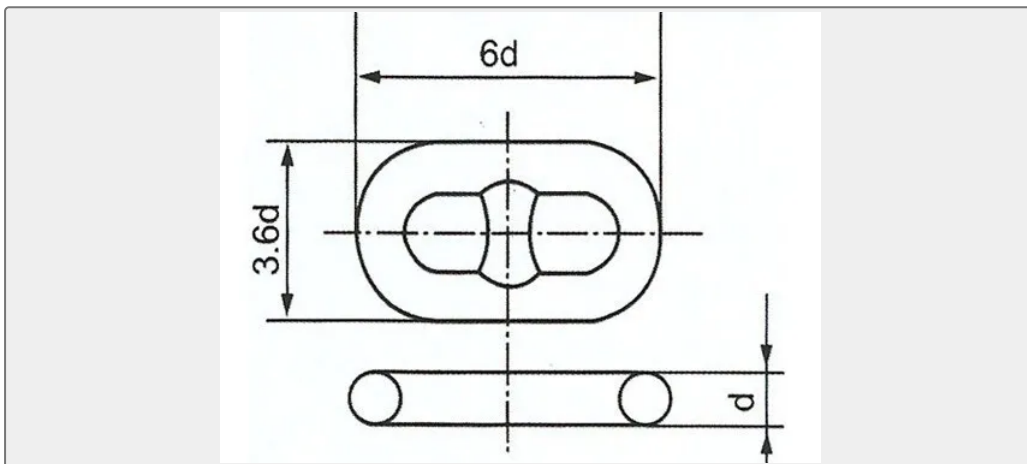

R5 Offshore Stud Link Mooring Chain is highest grade mooring chain for mooring system, with good performance in the sea water. This chains has been introduced for the higher requirement in the oil and gas offshore field.

Main Specification:

Size: 76mm-162mm

Grade: R5

Finish: Blacked painted.

Certificate: ABS, LR, BV, GL, RINA, DNV, NK, KR, CCS

Proof Load for R5 Offshore Stud Link Mooring Chain