

# Jinbo Marine

Marine &amp; Offshore Equipment Datasheet

PRODUCT DATASHEET

## GENERAL EMERGENCY ALARM SYSTEM

# SG-41B Electronic Bell(Square)

SG-41B Electronic Bell(Square) 1)Chapter 2 of Part 4 of the"Steel Ship Classification Rules" of the China Classification Society: 2)Chapter, of MSC.48(66) international life-saving&nbsp;appliance code(LSA),and i...

ISO9001 Supplier

Class Certificate

Export Supply



### Key Highlights

Category	General Emergency Alarm System
Standard	EN
Material	SG-41B Electronic Bell(Square) 1)Chapter 2 of Part 4 of the"Steel Ship ...
Certificate	ABS, LR, BV, DNVGL, NK, KR, IRS, RMRS, CCS

We can supply according to your requirement, drawings, class certificate needs, and delivery schedule.

### Technical Specifications

Category	General Emergency Alarm System	Model / SKU	SG-41B-Electronic-Bell-Square
Standard	EN	Material	SG-41B Electronic Bell(Square) 1)Chapter 2 of Part 4 of the"Steel Ship Classification Rules" of the China Classification Society:
Certificate	ABS, LR, BV, DNVGL, NK, KR, IRS, RMRS, CCS	Warranty	12 Months unless specified otherwise
Origin	China		

## China SG-41B Electronic Bell(Square):

SG-41B Electronic Bell(Square)

- 1)Chapter 2 of Part 4 of the"Steel Ship Classification Rules" of the China Classification Society;
- 2)Chapter, of MSC.48(66) international life-saving appliance code(LSA),and its amendment MSC.218(82);
- 3)IMO resolution A.1021 (26) code on alerts and indicators,2009.



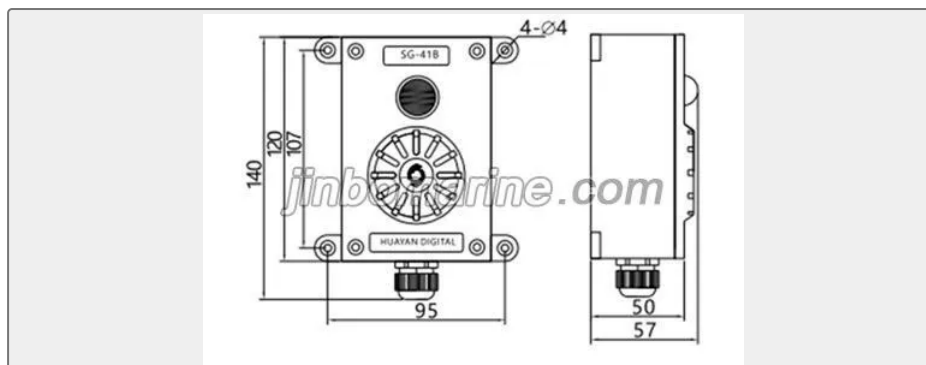

Colour: Red

Shell material: ABS

Cable gland: PG16

Power supply: AC220V±10% DC24V±10%

IP rating: IP56

Output power: 3-5w

Sound pressure level: 85~95dB