

Jinbo Marine

Marine & Offshore Equipment Datasheet

PRODUCT DATASHEET

YACHT & BOAT ACCESSORY

Snap-Hook-DIN5299-Form-C-SS304-OR-SS316-Steel-Electric-Galvanized-CSSH09

ISO9001 Supplier

Class Certificate

Export Supply

SIZE Φ A mm B mm C mm D mm F mm W.L.L LBS 4*40 4 20 40 ...

Key Highlights

Category	Yacht & Boat Accessory
Standard	DIN
Material	Stainless steel
Weight / Size	SIZE Φ A mm B mm C mm D mm F mm W.L.L LBS 4*40 4 20 40 7 7 80 5*50 5 25 5...
Certificate	ABS, LR, BV, DNVGL, NK, KR, IRS, RMRS, CCS

We can supply according to your requirement, drawings, class certificate needs, and delivery schedule.

Technical Specifications

Category	Yacht & Boat Accessory	Model / SKU	Snap-Hook-DIN5299-Form-C-SS304-OR-SS316-Steel-Electric-Galvanized-CSSH09
Standard	DIN	Material	Stainless steel
Weight / Size	SIZE Φ A mm B mm C mm D mm F mm W.L.L LBS 4*40 4 20 40 7 7 80 5*50 5 25 50 8 7 100 6*60 6 30 60 9 8 140 7*70 7 35 70 10 8 200 8*80 8 40 80 12 9 250 9*90 9 45 90 12 10 280 10*100 10 50 100 15 11 400 11*120 11 57 120 18 16 500 12*140 12 67 140 20 19 600 13*160 13 74 160 22 25 700 14*180 14 86 180 22 35 900	Certificate	ABS, LR, BV, DNVGL, NK, KR, IRS, RMRS, CCS
Warranty	12 Months unless specified otherwise	Origin	China

China Snap-Hook-DIN5299-Form-C-SS304-OR-SS316-Steel-Electric-Galvanized-CSSH09:

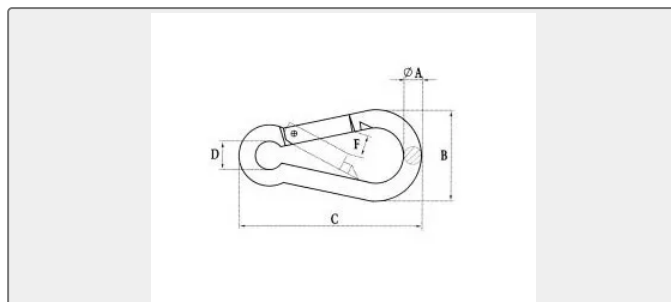

SIZE	ΦA mm	B mm	C mm	D mm	F mm	W.L.L LBS
4*40	4	20	40	7	7	80
5*50	5	25	50	8	7	100
6*60	6	30	60	9	8	140
7*70	7	35	70	10	8	200
8*80	8	40	80	12	9	250
9*90	9	45	90	12	10	280
10*100	10	50	100	15	11	400
11*120	11	57	120	18	16	500
12*140	12	67	140	20	19	600
13*160	13	74	160	22	25	700
14*180	14	86	180	22	35	900