

# Jinbo Marine

Marine &amp; Offshore Equipment Datasheet

PRODUCT DATASHEET

## CLEAR VIEW SCREEN

## WQ310 cleaner of rain and snow

WQ310 cleaner of rain and snow is driven by motor, used to clean the rain and snow with high speed disc, make sure the clear visual. Optional: Heating Device, please specify when order.

Main Specification ...

ISO9001 Supplier

Class Certificate

Export Supply



### Key Highlights

Category	Clear View Screen
Standard	EN
Weight / Size	Main Specification Power AC220V Frequency 50/60Hz Motor AC Single Phase ...
Certificate	CCS

We can supply according to your requirement, drawings, class certificate needs, and delivery schedule.

### Technical Specifications

Category	Clear View Screen	Model / SKU	WQ310-cleaner-of-rain-and-snow
Standard	EN	Weight / Size	Main Specification Power AC220V Frequency 50/60Hz Motor AC Single Phase Motor Power <=90W Heater Power <=250W Weight 13kgs Mounting Dimension(mm) Dia353
Certificate	CCS	Warranty	12 Months unless specified otherwise
Origin	China		

### China WQ310 cleaner of rain and snow:

WQ310 cleaner of rain and snow is driven by motor, used to clean the rain and snow with high speed disc, make sure the clear visual.

Optional: Heating Device, please specify when order.

#### Main Specification



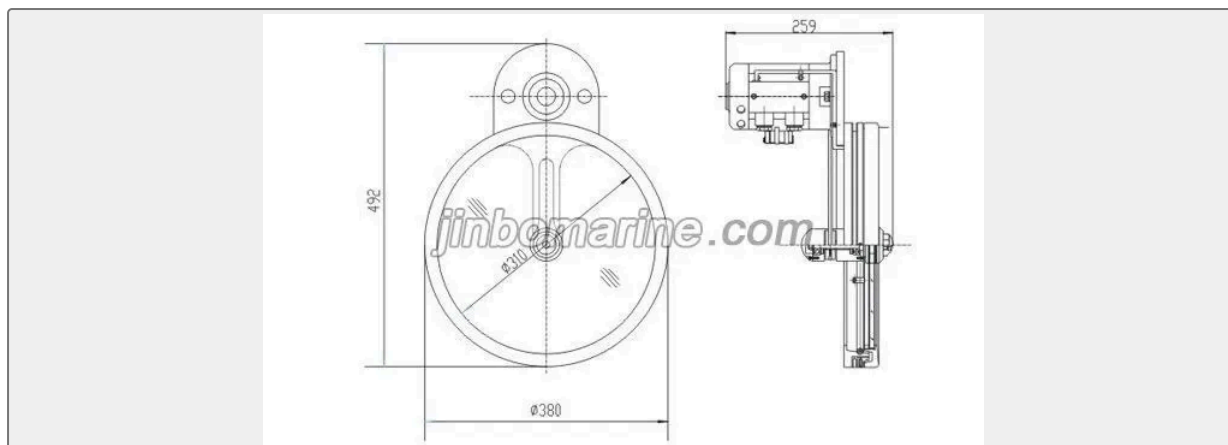

Power AC220V

Frequency 50/60Hz

Motor AC Single Phase

Motor Power  $\leq 90$ W

Heater Power  $\leq 250$ W

Weight 13kgs

Mounting Dimension(mm) Dia353

