

**PRESSURE WATER TANK**

# YLG Series Pressure Water Tank

Application: The pressure water unit can be used to provide fresh water for living and cleaning of ship and drilling platforms. Type Significance: A: Wall-hanging type, Repair entrance: barrel flange, B: Wall-h...

- ISO9001 Supplier
- Class Certificate
- Export Supply

	<div style="background-color: #1a3d3d; color: white; padding: 5px;"><b>Key Highlights</b></div> <table border="1" style="width: 100%; border-collapse: collapse; margin-top: 5px;"> <tr> <td style="padding: 5px;"><b>Category</b></td> <td style="padding: 5px;">Pressure Water Tank</td> </tr> <tr> <td style="padding: 5px;"><b>Standard</b></td> <td style="padding: 5px;">EN</td> </tr> <tr> <td style="padding: 5px;"><b>Certificate</b></td> <td style="padding: 5px;">CCS, EC, GL and BV certificate.</td> </tr> </table> <div style="margin-top: 10px; padding: 5px; background-color: #f0f0f0;"> <p>We can supply according to your requirement, drawings, class certificate needs, and delivery schedule.</p> </div>	<b>Category</b>	Pressure Water Tank	<b>Standard</b>	EN	<b>Certificate</b>	CCS, EC, GL and BV certificate.
<b>Category</b>	Pressure Water Tank						
<b>Standard</b>	EN						
<b>Certificate</b>	CCS, EC, GL and BV certificate.						

**Technical Specifications**

<b>Category</b>	Pressure Water Tank	<b>Model / SKU</b>	YLG-Series-Pressure-Water-Tank
<b>Standard</b>	EN	<b>Certificate</b>	CCS, EC, GL and BV certificate.
<b>Warranty</b>	12 Months unless specified otherwise	<b>Origin</b>	China

<b>CONTENTS</b>	<ul style="list-style-type: none"> <li>■ China YLG Series Pressure Water Tank:</li> <li>■ Main technical requirements:</li> </ul>	<ul style="list-style-type: none"> <li>■ Type Significance:</li> <li>■ Principle description:</li> </ul>
-----------------	---	--

## China YLG Series Pressure Water Tank:

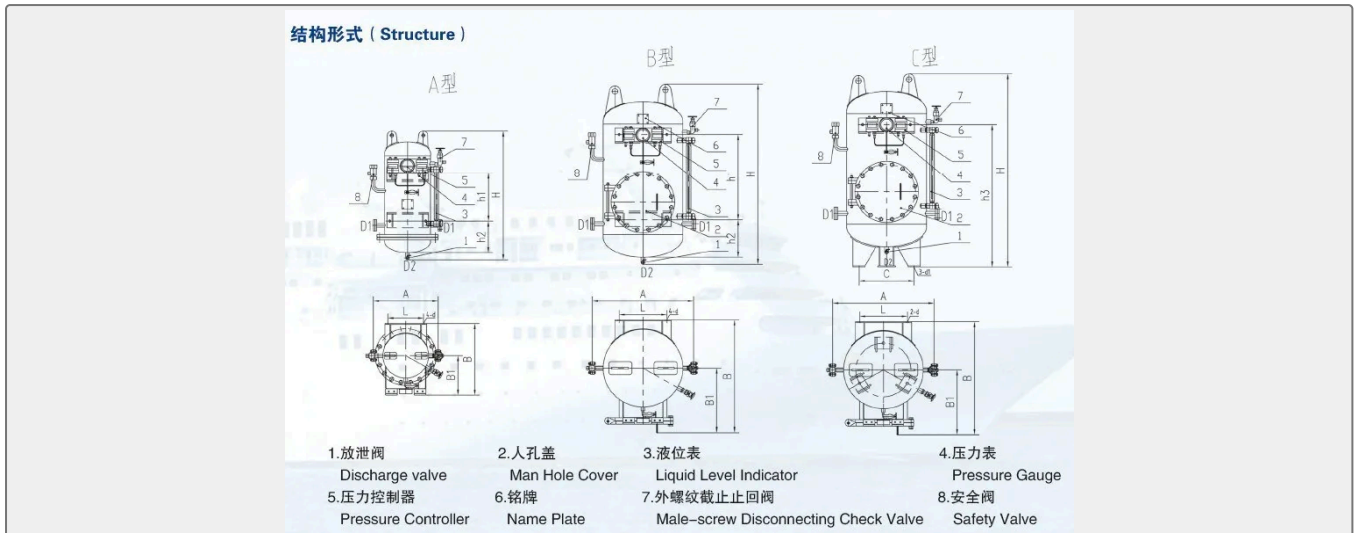

Application: The pressure water unit can be used to provide fresh water for living and cleaning of ship and drilling platforms.

### Type Significance:

A: Wall-hanging type, Repair entrance: barrel flange ,  
 B: Wall-hanging type, Repair entrance: barrel manhole ,  
 C: Vertical type, Repair entrance: barrel manhole.

### Main technical requirements:

Volume: 0.12-3.0m<sup>3</sup>

Working pressure: 0.6MPa

Design pressure: 0.7MPa

Strength test pressure: 1.05MPa

Air tightness test pressure: 0.875MPa

Open pressure of safety valve: 0.63MPa

Working temperature: 0~45°C

Design temperature: 50°C

### Principle description:

This device uses pressured water perersted by pump prouded by shipxard, to compress the air inside of tank, in order to maintain the water in cabinet body under a snitable air pressure. So as to provide fresh water to the crews.

Liquid level meter: to show the water level condition in tank.

Pressure gauge: to show the pressure in tank.

Pressure controller: to control the start and stop of water pump. When the pressure in tank is under 0.4Mpa, the water pump will start to feed water into tank until the pressure reaches 0.6Mpa.

Safety valve: When the pressure in tank is more than 0.63Mpa, the safety valve will open to release the pressure in tank.

Charge valve: to charge the compressed air into tank.

Discharging valve: to empty the water in tank when maintaining.

