

## CB436-2000 A type Cleat fairlead with single roller



It is used for guiding ropes in ship mooring and will not breakdown.

Complete with a primer paint finish our Warping Roller (also know as Fairlead roller) are immediately ready for any vessel installation. Cast from the finest quality steel for added durability, our fairlead roller range utilises a combination of horizontal and vertical rollers to give you a comprehensive solution for your needs.

It is used for bollard cable leading of ships

good wear and corrosion resistance to grant a long service time

All products can be designed according to customers requirements.

The breaking load of tight wire is the highest.

Compact design,precision machined smooth surface,easily removable shafts,

Combination type including double warping roller with plate, three warping roller with plate and more.

Paint: Grey Epoxy Primer, for the middle paint and surface according to your requirement.

Delivery time:7-15 days after order be confirmed.

Machining facilities :CNC center, CNC lathes, ultrasonic wave cleaning etc

Drawing:

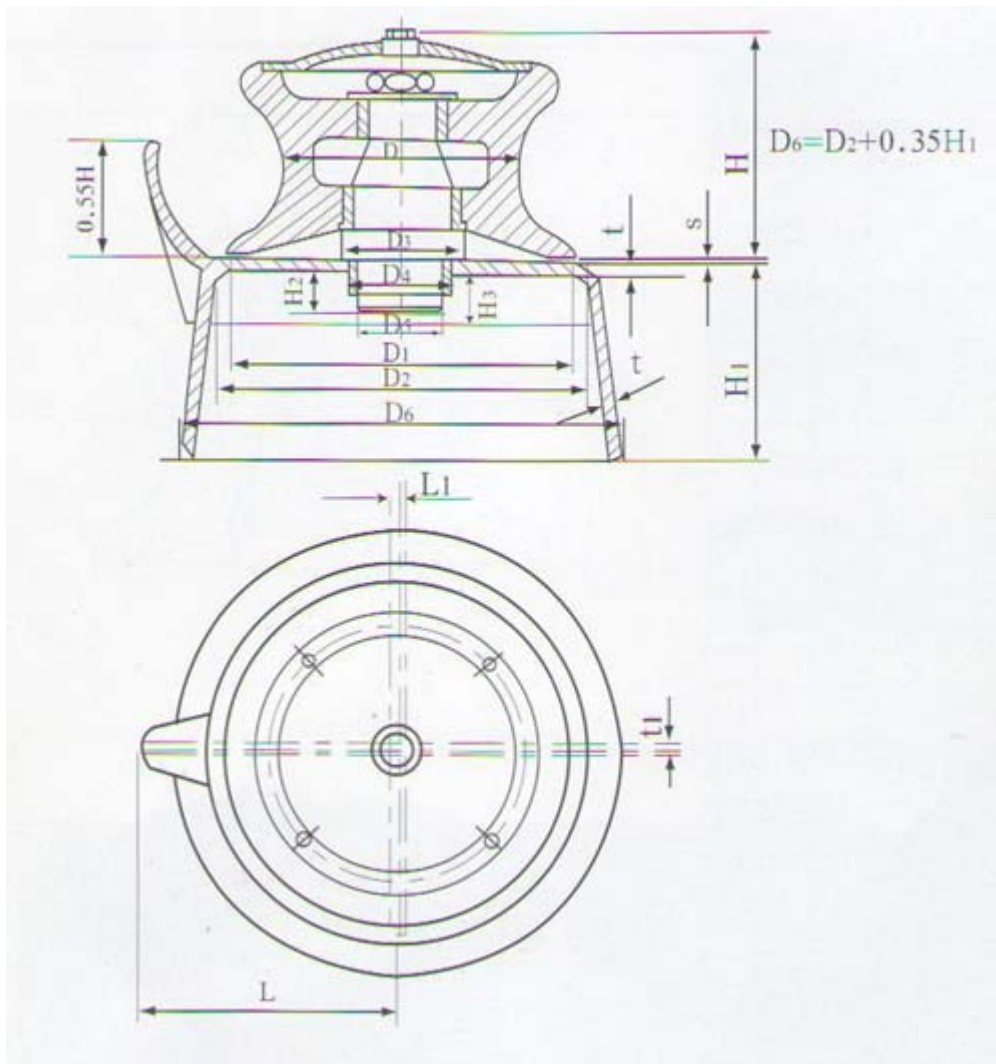

**Size chart:**

CB436-2000 A type Cleat fairlead with single roller																			
Product No.	Nominal Size(m)	Steel rope GB1102 Breaking Load 1520N/mm <sup>2</sup>			Dimension									Roller weight KG	Base weight kg H1=100				
		6*2	6*3	6*3	D1	D2	D3	D4	D5	L	H	H1	H2			H3	St	t1	Ca st iron
CBRA-001	150	17	17.5	15	240	270	90	71	60	245	211		40	75	32	18	32.1	33.8	129
CBRA-002	200	22.5	21.5	19.5	310	340	115	95	80	285	251	The base height is as per your request	50	85	34	14	64.0	68.6	178
CBRA-003	250	24	26	24	380	410	140	107	90	323	298		60	100	44	14	108	114	207
CBRA-004	300	30	32.5	28	440	470	160	127	110	355	321		60	100	46	14	159	168	265
CBRA-005	350	37.5	39	34.5	500	530	180	144	125	390	346		65	100	48	14	235	248	332
CBRA-006	400	41	39	39	560	590	200	161	140	420	371		70	100	50	16	336	355	401

CB436-2000 A type: Adopt CB 58-83 fairlead roller